

Frascold®



Semi-Hermetic

Reciprocating Compressors





FCAT100_EN_07 (v1)

Catalog Index

• Index - About Frascold	3
• Reciprocating Compressors Overview	4
• Applications	5
• Install Safety. Model Numbers. Compressor Envelope	6
• VFD Use. Lubricating Oil	7
• Standard Equipment and Optional Accessories	8
• Asercom Certification	9
• Special Features	10
• Range of Models	12
• Models for Special Applications	13
• Capacity Control	14
• Selection Software	16
• Protection	18
• Technical Data	20
• Operational Limits	26
• Dimensional Drawings	30

Frascold - Since 1936

A global leader in the industry for over 80 years. Frascold produces over 70.000 screw and reciprocating compressors a year. Our 53.000 m² square foot factory outside of Milan. Italy houses our advanced engineering, manufacturing and testing facilities.

Frascold has subsidiaries in the United States, China and India, and partners in 86 countries. We are the second largest semi-hermetic compressor manufacturer in Europe, and the third largest in the world.

We are committed to our customers, our employees and our values of innovation, quality and service. We are passionate about being the best, and strive to improve and refine whenever possible. Investing in ourselves and our partners has made us the world's premier compressor manufacturer.



Frascold is a member of **ASERCOM**, the Association which ensures the accuracy and reliability of compressor performance and that has set out the procedure for measuring the performance of compressors and their certification process. The certification of compressors guarantees that the performance published corresponds to that actually measured with reference to European standard EN12900. The compressors with certified performance are listed on ASERCOM's certified compressor list.

Frascold reserves ownership of this catalog, no reproduction is allowed without our explicit consent. The data and information contained in the brochure were determined based on our current capabilities and do not exempt the user from his duty to check the suitability of the products for the intended application. Frascold reserves the right to change the content of the catalogue as a consequence of normal innovations and updates deemed necessary.

Semi-Hermetic

Reciprocating Compressors

Product Line Overview

Standard semi-hermetic reciprocating compressors range from 0.5 to 80 hp and are designed with performance, reliability and efficiency in mind. This product line consists of 8 Series comprised of 86 models. All models are also compatible with our revolutionary new **Reduced Suction Head (RSH)** capacity control system and are suitable for variable frequency drive use.

2 Cylinders

A, B & D Series

22 Models
3.9 - 19.1 m³/h
0.5 - 4 HP

4 Cylinders

Q, S & V Series

43 Models
19.8 - 102.9 m³/h
4 - 35 HP

6 Cylinders

Z Series

11 Models
106.1 - 154.4 m³/h
25 - 50 HP

8 Cylinders

W Series

11 Models
141.5 - 238 m³/h
40 - 80 HP

- 2 year warranty standard
- Most models ASERCOM certified
- Space-saving compact footprint
- High efficiency and low noise
- HFOs and natural refrigerants
- HFCs and new low GWP refrigerants
- R134a, R1234ze & R1234yf optimized models
- TWIN configuration available
- Two-stage models available
- Transcritical & subcritical CO₂ models
- Advanced protection system
- Integrated VFD available (VS models)
- Optional RSH capacity control
- All models VFD compatible

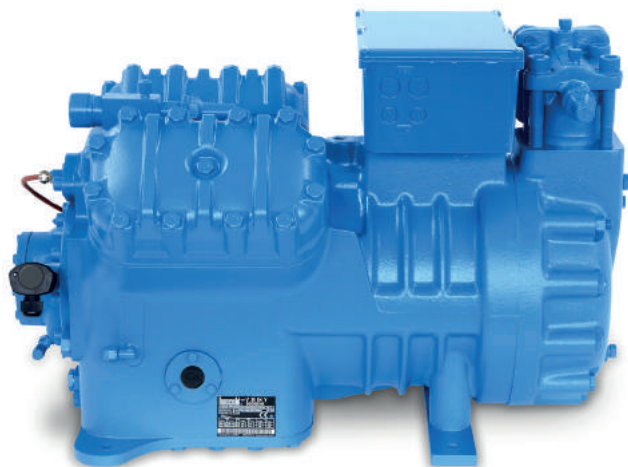

In addition to standard models, we carry ECOinside models optimised for R134a, R1234ze & R1234yf, explosion-proof ATEX models, VS models with integrated inverter, subcritical and transcritical CO₂ models, two-stage and TWIN configuration models.

Standard Applications

With a wide range of innovative models, Frascold has the right compressor for any application. Numerous options and accessories increase the versatility of our already extensive lineup. A compact footprint, low noise, high efficiency and low operating cost make our compressor the ideal choice. Our compressors come equipped with the most advanced protection system in the industry and carry a standard 2 year warranty. Find out why blue is better.

- Air conditioning
- Industrial refrigeration
- Retail cooling systems
- Pharmaceutical manufacturing
- Liquid chillers
- Process chillers
- Transport refrigeration
- Marine cooling systems
- Cryogenic systems
- Heat pumps



Installation Safety

Frascold compressors are constructed according to International safety standards. They may only be used if installed within systems complying with the operating instructions and conforming to the regulations in force. For the relevant standards please refer to the Manufacturer's Declaration, available on the www.frascold.it website in the documentation section. They will be put into service by experienced staff. Suitably documented in relation to the manufacturer's declarations and able to understand and apply the instructions contained in the installation manual supplied with the compressor or available on the www.frascold.it website.

Model Numbers

Every Frascold compressor has a data plate indicating the model series, motor type, oil charge and displacement. This diagram explains the designation on a typical data tag.

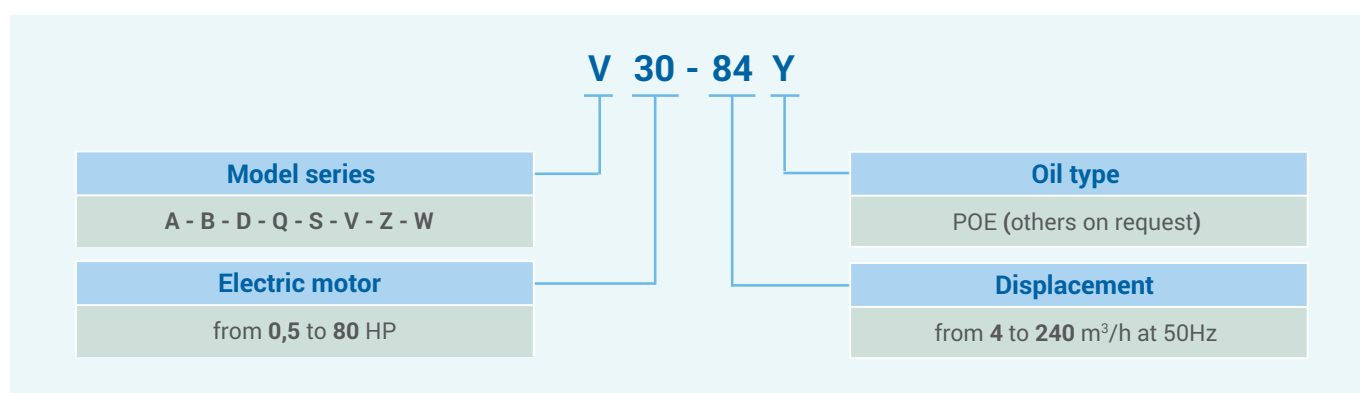

Compressor Envelope

Diagrams published in this catalog are to be considered as a general diagram for the full range of semi-hermetic reciprocating compressors. For specific model and refrigerant performance data, please use the **FSS.3 Frascold Selection Software** available for free download at www.frascold.it.

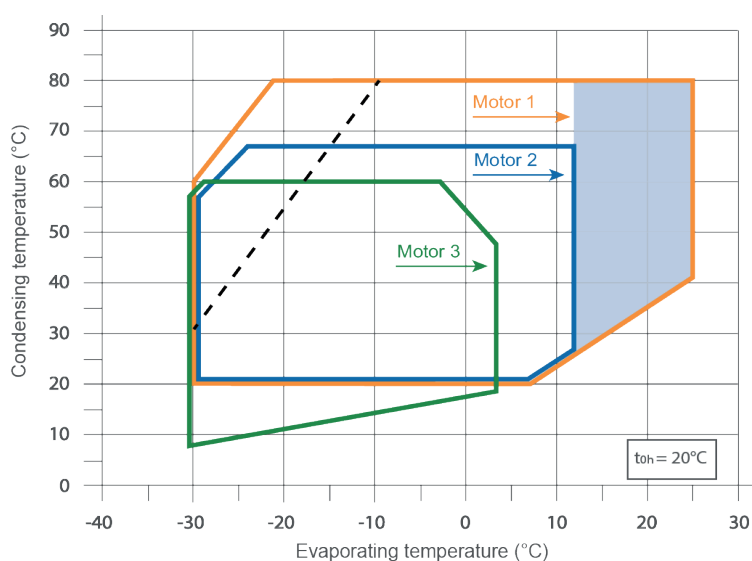

- Motor 1** - Medium temperature applications
- Motor 2** - Low temperature applications
- Motor 3** - Medium temp for R134a & R1234ze

Application with Variable Frequency Drive

While our VS series compressors are supplied with an integrated inverter, all Frascold compressors are designed to be compatible with inverter technology. Inverters, also known as variable frequency drives, can greatly improve performance and efficiency in many applications.

- 2 cylinder models: capacity control from 60% to 174% (30Hz - 87Hz)
- 4 cylinder models with centrifugal lubrication: capacity control from 60% to 140% (25Hz - 87Hz)
- 4 cylinder models with forced lubrication: capacity control from 50% to 174% (30Hz - 70Hz)
- 6 and 8 cylinder models: capacity control from 60% to 140% (30Hz - 70Hz)

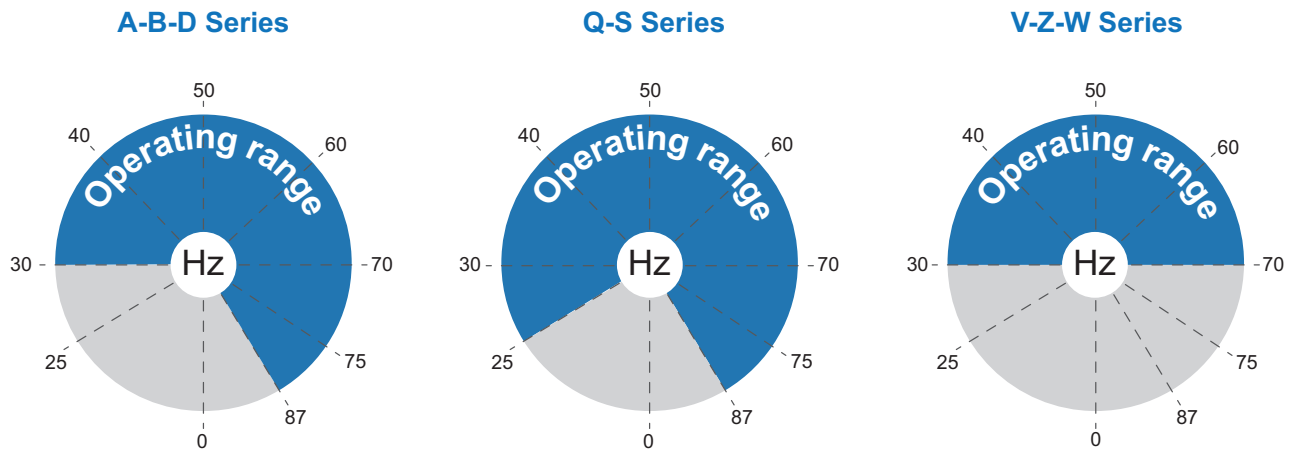

For 400V motors, in certain application conditions there might be a narrowing of the frequency range. Always check on the Frascold Selection Software. For capacity data at the various frequencies see the Frascold selection software FSS.3.

Lubricating Oil

All compressors are supplied with a standard oil charge, but alternative oil charges for specific applications are available on request. For details on oil specifications please refer to Frascold technical and usage information document FTEC022 available for download on the www.frascold.it website.

Compressor	Oil Type	Alternative Oil	Base	Viscosity at 40°C (cSt)	Refrigerant	Application
A, B, D, Q and S Series	Frascold 32POE	Emkarate RL32H or equivalent	POE	32	HFO, HFC, R22	Low, Medium and High Temp
V, Z and W Series	Frascold 68POE	Emkarate RL68H or equivalent	POE	68	HFO, HFC, R22	Low, Medium and High Temp
A, B, D, Q, S, V and Z Series	Frascold 68PAG	CPI 1516-68 or equivalent	PAG	68	HFO, HFC, R22	Low, Medium and High Temp
W Series	Frascold 150PAG	CPI 1516-150 or equivalent	PAG	150	HFO, HFC, R22	Low, Medium and High Temp

Standard equipment and optional accessories

Description	Series						
	A - B	D	Q	S	V	Z	W
Semi-hermetic compressor with built-in electric motor direct on line start (DOL) and PTC or AMS thermal protections 220-240V Δ / 380-420V λ / 3 / 50 Hz 265-290V Δ / 440-480V λ / 3 / 60 Hz	S PTC	S PTC	S AMS				
Semi-hermetic compressor with built-in electric motor. part winding start (PWS) and PTC or AMS thermal protections 380-420V λ / 3 / 50 Hz 440-480V λ / 3 / 60 Hz				S AMS	S AMS	S AMS	S PTC
Electric terminal box IP class protection	IP56	IP56	IP56	IP56	IP65	IP65	IP65
Control and protection device	S	S					
Control, diagnostics & protection device	▲	▲	S	S	S	S	S
Discharge temperature control sensor			▲	▲	S	S	S
Electronic oil differential pressure switch					S	S	S
Reversible oil pump					S	S	S
Oil level sight glass	S [x1]	S [x1]	S [x2]	S [x2]	S [x2]	S [x2]	S [x2]
Oil charge	POE32	POE32	POE32	POE32	POE68	POE68	POE68
Liquid injection connection			S	S	S	S	S
Suction shut-off valve	S	S	S	S	S	S	S
Discharge shut-off valve	S	S	S	S	S	S	S
Nitrogen charge (2bar min)	S	S	S	S	S	S	S
Rubber supports	S	S	S	S	S	S	S
Oil heater	▲	▲	▲	▲	▲	▲	▲
US unloader start head		▲	▲	▲	▲	▲	▲
RSH capacity control head		▲	▲	▲	▲	▲	▲
CC capacity control head			▲	▲	▲	▲	▲
Head cooling fan	▲	▲	▲	▲	▲	▲	▲
Water cooled head	▲	▲	▲	▲	▲	▲	▲
Liquid injection kit (FLI)			▲	▲	▲	▲	▲
Optoelectronic oil level switch	▲	▲	▲	▲	▲	▲	▲
Electronic oil level regulator	▲	▲	▲	▲	▲	▲	▲
Kit adapters for oil equalization line	▲	▲	▲	▲	▲	▲	▲
DP-Modbus Gateway	▲	▲	▲	▲	▲	▲	▲
Connection cable Modbus Gateway - INT69	▲	▲	▲	▲	▲	▲	▲
USB adapter cable			▲	▲	▲	▲	▲

S Standard supplied

▲ Optional accessories

ASERCOM

Certification

What is ASERCOM

ASERCOM (Association of European Refrigeration Component Manufacturers) promotes standards for safety and performance ratings in the refrigeration industry. ASERCOM certification means that a compressor's performance has been determined to meet the specifications stated by its manufacturer.

How It Works

Manufacturer's performance data for a particular compressor model and refrigerant are submitted to ASERCOM for certification. To ensure objectivity, members of the certification committee are selected from competing manufacturers. If the committee agrees with the submitted performance data that model is added to the certified list.



Performance Testing

Models from the certified list are regularly tested to verify performance. To ensure fairness, the compressor to be tested is obtained from a distributor's stock and tested at a competitor's facility. If test results are not up to listed specifications that model is removed from the certified list.

Frascold stands behind the quality, performance and reliability of all of our products. We currently have 108 ASERCOM certified models and more on the way. All of our compressors are run tested at the factory and carry a standard 2 year warranty.

Special Features

Reciprocating Compressors

Capacity regulation possible on all Frascold semi-hermetic reciprocating compressors using standard unloading heads, VFDs or Frascold's exclusive Reduced Suction Heads (RSH). A wide operating range allows the use of a single model for both low and medium temperature applications. Perfect mechanical balancing means low vibration, pulsation and noise. Attention to detail really sets our compressors apart and helps make us the worlds premier compressor manufacturer.

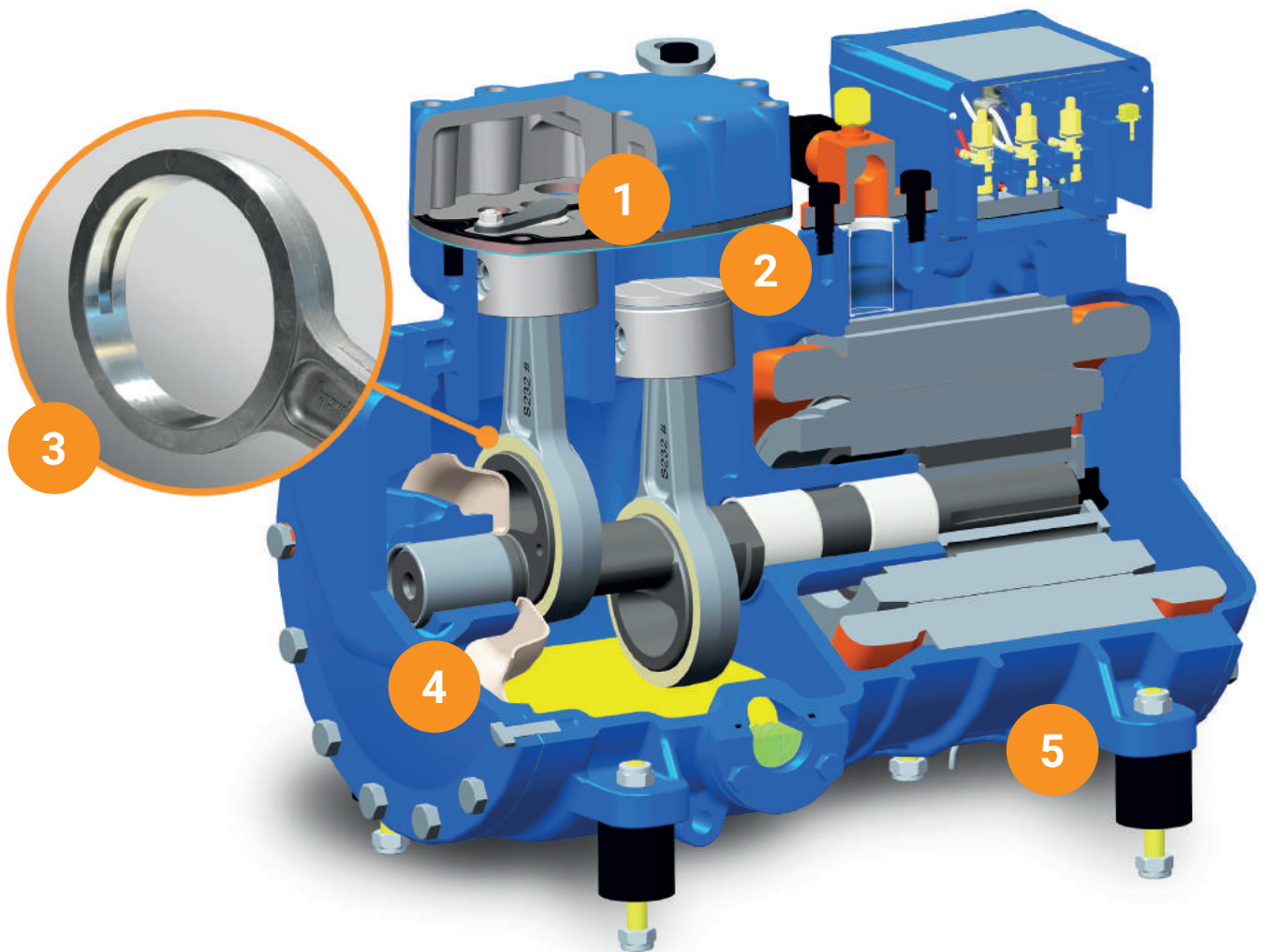

1. Suction and discharge ports optimized to prevent oil sticking effect, improving efficiency
2. Piston heads are machined to precisely match suction needs for higher efficiency
3. Oil reservoir machined into connecting rod aids lubrication on startup
4. Splash lubrication system on A, B, D, Q and S series compressors
5. Compact footprint requires less installation space

Models available for standard HFC and HFO refrigerants as well as new low GWP blends and hydrocarbons. Compressors from the Q, S, V, Z and W series are available with three different motor sizes to suit particular applications. Twin configuration is available on our Q, Z and W series compressors.

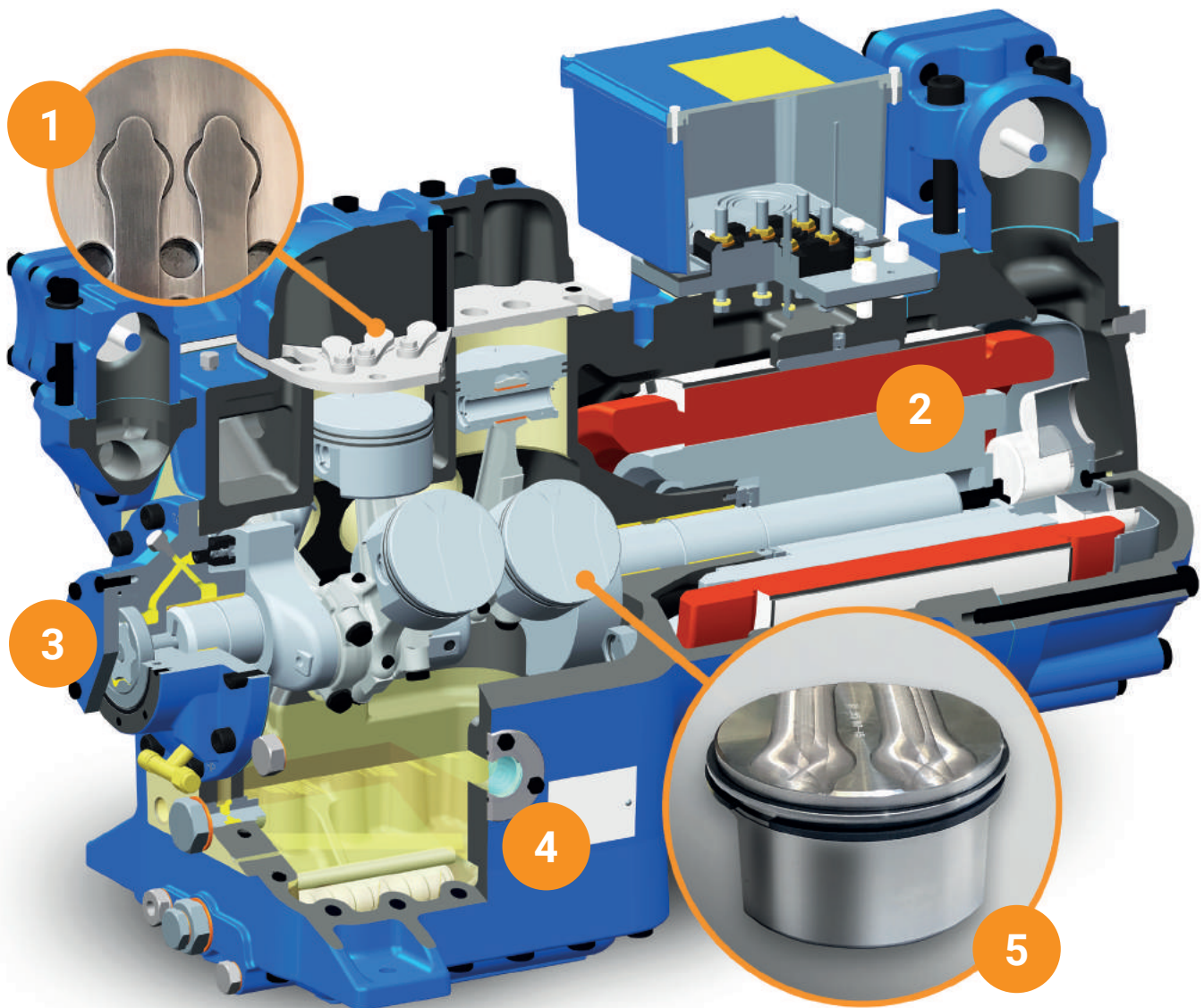

1. Suction and discharge ports optimized to prevent oil sticking effect. improving efficiency
2. Three different motor sizes are available on Q, S, V, Z and W series for specific applications
3. Forced lubrication system on V, Z and W series compressors.
4. Sight glass on both sides of crankcase
5. Piston heads are machined to precisely match suction reeds for higher efficiency

Range of models

Semi-hermetic reciprocating

Standard Models

The range of Frascold semi-her reciprocating compressors includes models with 2, 4, 6 and 8 cylinders for refrigeration in low and medium temperature, process cooling, air conditioning and heat pump applications. To select the right model, use the free Frascold FSS.3 selection software and the many publications available on the www.frascold.it website.

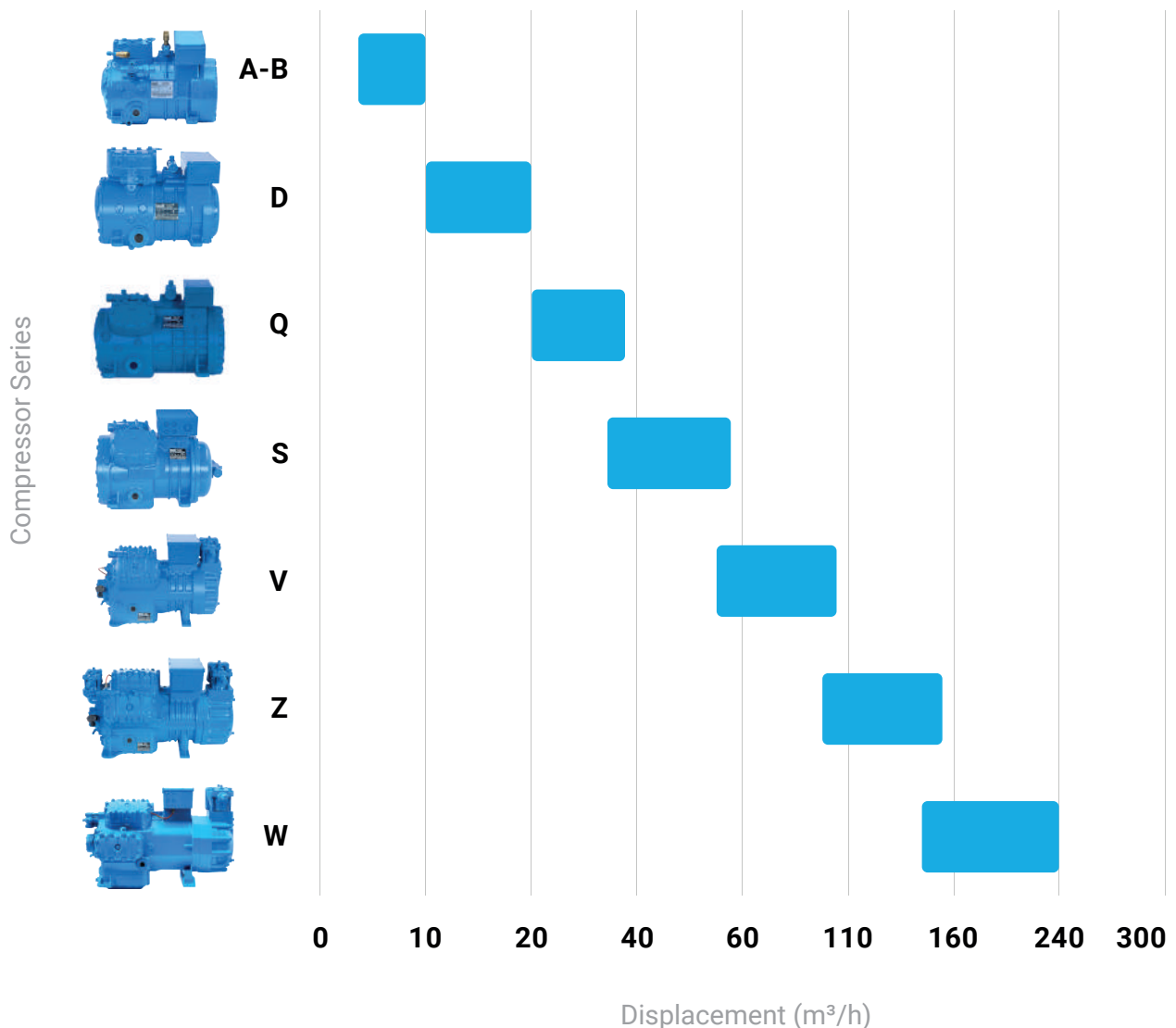

Compressors for special applications

In addition to our extensive line of standard compressors, Frascold also produces several lines of specialty type compressors. From our VS series with integrated VFD to our two-stage compressors to our ATEX series of explosion proof compressors, we have a solution for every application. Our specialty compressors showcase our dedication to innovative design and advanced manufacturing.



Inverter Compressors

Our VS series compressors come factory equipped with inverter (frequency drive). Cooling capacity can be precisely varied to suit demand, drastically improving energy efficiency. Inverter is factory pre-programmed but can be customized to suit specific application, 9 models available from 1.5 to 7.5 hp. For more information please refer to catalog FCAT01VS.

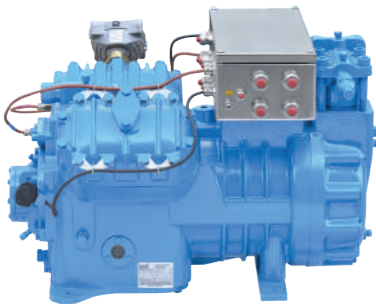

ATEX Compressors

To meet the ATEX standards required in applications in explosive atmospheres, Frascold offers a wide range of models certified in accordance with directive 2014/34/UE. All Frascold ATEX compressors are also approved for use with hydrocarbons (R290 and R1270), 85 models available from 0.5 - 80 hp. For more information please refer to catalog FCAT24.

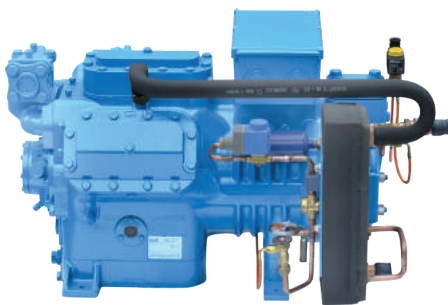

Two-stage Compressors

Frascold produces a range of compressors with double compression stage optimized for low-temperature applications and deep freezing. Available in 4 and 6-cylinder models, our two-stage compressors feature innovative design and unique control and protection features, 7 models available from 5 - 30 hp. For more information please refer to catalog FCAT105.

Capacity Regulation

Reciprocating Compressors

Reduced Suction Heads

Frascold's patented **Reduced Suction Head (RSH)** unloading technology represents a revolution in capacity control in reciprocating compressors. By allowing 50% gas flow to the unloaded cylinder head, our patented **RSH** system avoids problems encountered in traditional unloading.

RSH equipped systems can run unloaded indefinitely with no additional vibration or compressor damage. This allows the system to more accurately match fluctuating cooling demand, thus saving a significant amount of energy over traditional unloading. Reducing the number of start-stop cycles dramatically decreases wear and tear on the compressor and motor.

Standard unloading blocks gas flow to one or more cylinder heads to temporarily reduce cooling capacity. This method is not nearly as energy-efficient and can cause mechanical issues. Blocking gas flow causes the compressor to run in a partial vacuum, causing vibration, heat and stress.

Patented Technology

RSH unloading is available exclusively from Frascold and can be fitted to any Frascold reciprocating compressor (2, 4, 6 and 8 cylinders). The reduced vibration and noise while running unloaded is noticeable when compared to compressors not equipped with this technology.

RSH Unloading Steps

With more unloading steps and the ability to run unloaded indefinitely, **RSH** equipped systems provide greater application flexibility and energy costs can be significantly reduced. Fewer start-stop cycles means increased service life, less down time and lower maintenance costs.

RSH Heads	2 Cylinder	4 Cylinder	6 Cylinder	8 Cylinder
1	50 / 100%	75 / 100%	83 / 100%	87.5 / 100%
2		50 / 75 / 100%	66 / 83 / 100%	75 / 87.5 / 100%
3			50 / 66 / 83 / 100%	62.5 / 75 / 87.5 / 100%
4				50 / 62.5 / 75 / 87.5 / 100%

RSH Features & Advantages

- Suitable for HFC, HFO, HC and CO₂
- Improved system efficiency
- Longer compressor life
- Reduced on-off cycles
- Better suction pressure stability
- More capacity regulating steps
- Retrofit existing compressors
- Run unloaded indefinitely
- No increase in vibration or noise
- No overheating on discharge
- No oil carry-over

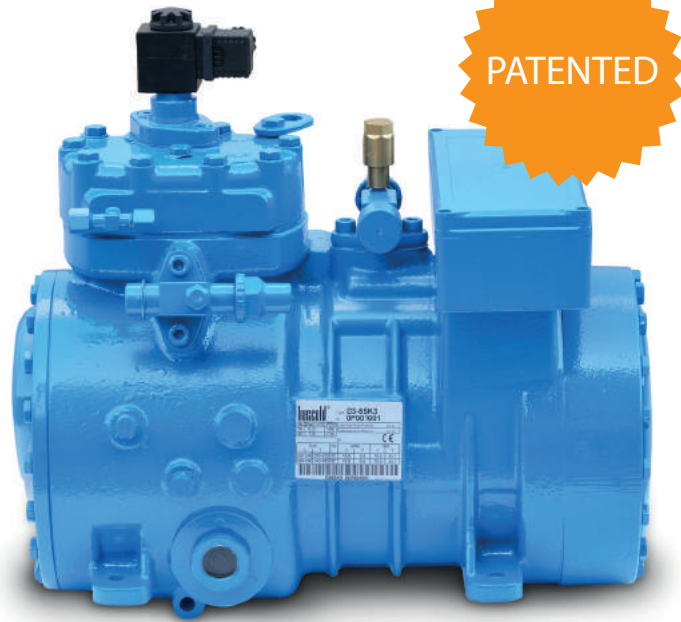

Our exclusive **RSH** heads can also be retrofitted to existing Frascold compressors, bringing a new level of performance and reliability to systems already in the field.

Standard Capacity Control

Frascold also offers a standard capacity control feature. Available on request on 4, 6 and 8-cylinder compressors. capacity may be adjusted by choking the heads in order to adapt the cooling capacity of the system to the actual thermal demand. This reduces the start-up frequency and the stress on the compressor mechanics and electric motor. Possible control stages:

- **4-cylinder models: 50% - 100% (2 steps)**
- **6-cylinder models: 33% - 66% - 100% (2 or 3 steps)**
- **8-cylinder models: 50% - 66% - 100% (2 or 3 steps)**

Protection

Reciprocating Compressors

Discharge temperature cutoff

The discharge temperature, in certain extreme conditions (such as high condensing temperatures, low evaporator pressures or extremely high compression ratios), may reach values that can damage the compressor. All V, Z and W series models are supplied with a safety device which, in combination with the electronic control module, stops the compressor in the event that the discharge temperature exceeds the set safety limit.

Electronic safety device to control lubrication

Frascold compressors in the V, Z and W series are supplied complete with an electronic pressure switch to control lubrication. It efficiently monitors the differential pressure in the lubrication system and stops the compressor in the event of any detected measurement that does not comply with the set safety values. The device is attached directly to the compressor's oil pump and does not require additional fittings.

Unloaded start

In Frascold compressors, the compressor can be started unloaded through the US device integrated in the head (available on request). The device equalises the suction and discharge pressure, thus reducing the starting torque on the compressor reducing absorption peaks from the electrical mains. Note: a check valve, not supplied by Frascold, must be installed after the discharge valve.

Compressor Protection: Series A, B & D

Standard protection equipment on A, B and D series compressors consists of a chain of PTC or AMS thermistors inserted in the electric motor stator and connected to the **Kriwan INT69** electronic control module inside the electrical box. The **INT69** device is triggered and stops the compressor in the event of thermal overload due to electric motor or mechanical issues. A, B and D series compressors can be optionally equipped with the Kriwan **INT69 Diagnose**.

Compressor Protection: Series Q & S

Frascold Q and S series compressors come standard with the **Kriwan INT69 Diagnose** protection device. This provides all of the protection of the **INT69**, but adds advanced diagnostic and communication functions, allowing the compressor to be remotely monitored in real time via modbus.

System conditions are monitored and the compressor is stopped in the event of incorrect functional parameters. Detailed reporting allows quick identification of the cause of the malfunction. Stored data allows technicians to accurately and quickly diagnose the past and present state of the cooling system, ensuring fast and cost-effective servicing with short system downtime.

Compressor Protection: Series V, Z & W

Frascold V, Z and W series compressors come standard with the **Kriwan INT69 TML Diagnose** protection device. This unit provides all of the protection data logging and remote monitoring capabilities of the **INT69** and **INT69 Diagnose** but with the addition of lubrication protection.

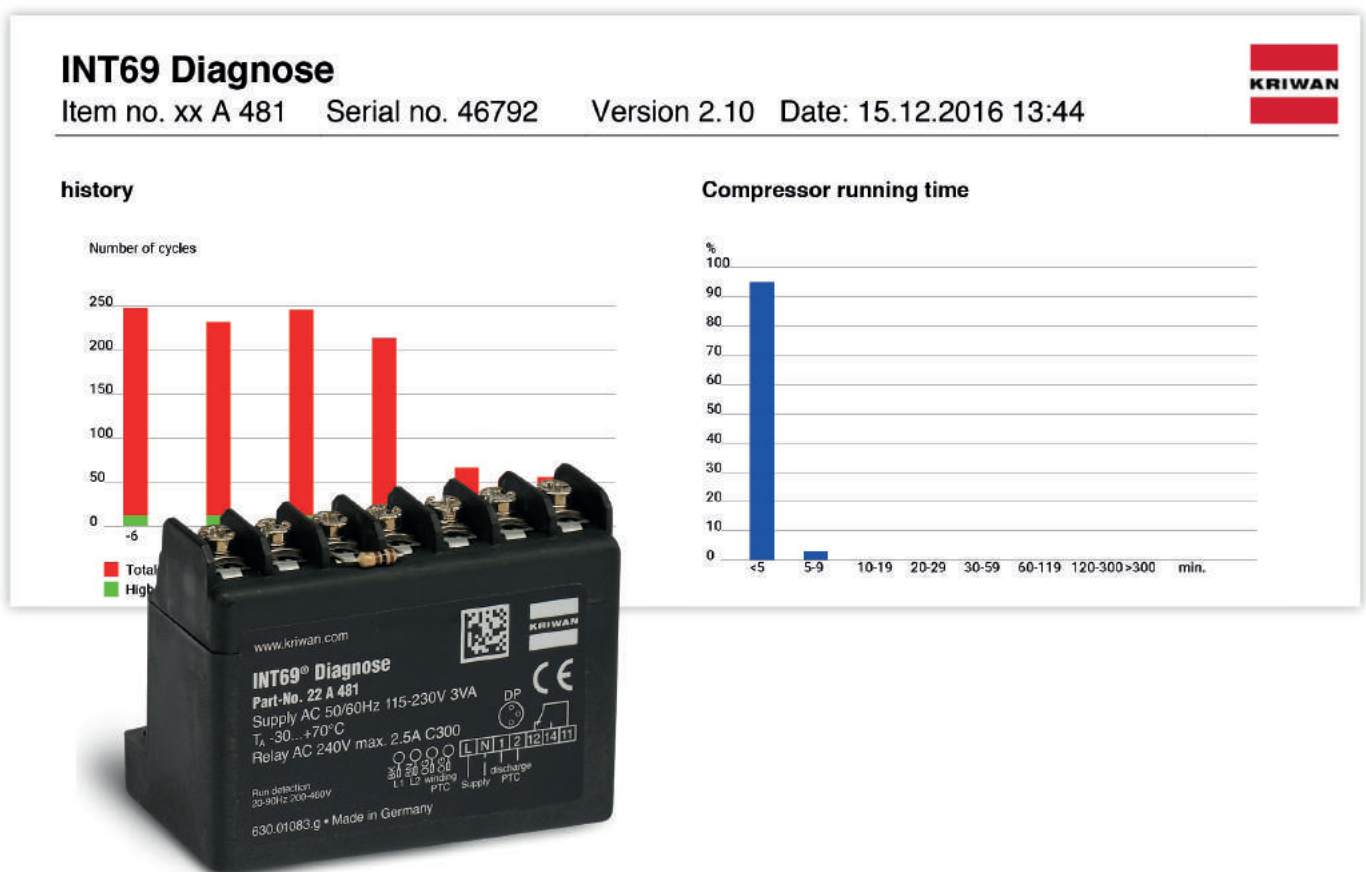

Kriwan **Diagnose** devices used on Q, S, V, Z & W series compressors, provide detailed operational information and error logs. This data can be used to aid in system optimization, identify problems and prevent malfunctions before they happen.

Technical Data

Reciprocating Compressors

Compressor Model		A05-4Y	A05-5Y	A07-5Y	A07-6Y	A1-6Y	A1-7Y	A1.5-7Y	A1.5-8Y
Cylinders		2	2	2	2	2	2	2	2
Displacement @ 50Hz	m ³ /h	3.95	4.93	4.93	5.47	5.47	6.91	6.91	7.65
Oil Charge (3/4 of sightglass)	litre	1	1	1	1	1	1	1	1
Electrical data									
Motor version		1	2	1	2	1	2	1	1
Connections		1	1	1	1	1	1	1	1
MRA max operating current 230V / 50Hz	A	4.9	4.7	4.7	4.9	6.2	6.4	7.9	8.4
MRA max operating current 400V / 50Hz	A	2.8	2.7	2.7	2.8	3.6	3.7	4.5	4.8
Max power consumption	kW	1.6	1.5	1.5	1.6	2.0	2.1	2.3	2.3
LRA max starting current 230V / 50Hz - 280V / 60Hz DOL motor	A	18.6	18.6	18.6	18.6	23.6	23.6	35.8	35.8
LRA max starting current 400V / 50Hz - 460V / 60Hz DOL motor	A	10.7	10.7	10.7	10.7	13.6	13.6	20.6	20.6

Compressor Model		B1.5-9.1Y	B1.5-10.1Y	B2-10.1Y	D2-11.1Y	D2-13.1Y	D3-13.1Y	D2-15.1Y	D3-15.1Y
Cylinders		2	2	2	2	2	2	2	2
Displacement @ 50Hz	m ³ /h	8.96	9.9	9.9	11.3	13.2	13.2	15.4	15.4
Oil Charge (3/4 of sightglass)	litre	1	1	1	1.1	1.1	1.1	1.1	1.1
Electrical data									
Motor version		2	2	1	1	2	1	2	1
Connections		1	1	1	1	1	1	1	1
MRA max operating current 230V / 50Hz	A	10.2	9.5	11.7	12.4	12.4	15.3	14.6	17.2
MRA max operating current 400V / 50Hz	A	5.9	5.5	6.7	7.1	7.1	8.8	8.4	10.1
Max power consumption	kW	3.3	3.1	3.6	4.1	4.1	4.8	4.7	5.7
LRA max starting current 230V / 50Hz - 280V / 60Hz DOL motor	A	46.6	46.6	62.5	62.5	62.5	79.9	62.5	75.9
LRA max starting current 400V / 50Hz - 460V / 60Hz DOL motor	A	26.8	26.8	35.9	35.9	35.9	43.7	35.9	43.7

Connections:

1 = 220-240V (Δ) - 380-420V (Y) / 3ph / 50Hz and 265-290V (Δ) - 440-480V (Y) / 3ph / 60Hz

2 = 380V-420V (Y/YY) / 3ph / 50Hz and 440V-480V (Y/YY) / 3ph / 60Hz

Tolerance ±10% based on mean value of voltage range. Other voltages upon request.

The indicated data refers to operation 50 Hz.

For 60Hz and other power supply voltage refer to FSS.3 selection software.

To select the contactors, cables and fuses, consider the maximum operating current and maximum input power.

Use AC3 Category contactors.

Compressor Model		D3-16.1Y	D4-16.1Y	D3-18.1Y	D4-18.1Y	D3-19.1Y	D4-19.1Y	Q4-20.1E	Q4-20.1Y
Cylinders		2	2	2	2	2	2	4	4
Displacement @ 50Hz	m ³ /h	16.4	16.4	17.9	17.9	19.1	19.1	19.8	19.8
Oil Charge (3/4 of sightglass)	litre	1.1	1.2	1.1	1.2	1.1	1.2	1.6	1.6
Electrical data									
Motor version		2	1	2	1	2	1	3	2
Connections		1	1	1	1	1	1	1	1
MRA max operating current 230V / 50Hz	A	17.2	20.1	17.3	21.7	17.0	20.5	10.6	17.5
MRA max operating current 400V / 50Hz	A	9.9	11.6	10.0	12.5	9.8	11.8	6.1	10.1
Max power consumption	kW	5.4	6.2	5.5	6.7	5.4	6.4	3.1	5.7
LRA max starting current 230V / 50Hz - 280V / 60Hz DOL motor	A	75.9	90.3	75.9	90.3	75.9	90.3	97.8	92.6
LRA max starting current 400V / 50Hz - 460V / 60Hz DOL motor	A	43.7	52.0	43.7	52.0	43.7	52.0	56.3	53.2

Compressor Model		Q4-21.1Y	Q5-21.1Y	Q4-24.1E	Q4-24.1Y	Q5-24.1Y	Q4-25.1Y	Q5-25.1Y	Q7-25.1Y
Cylinders		4	4	4	4	4	4	4	4
Displacement @ 50Hz	m ³ /h	21.2	21.2	23.9	23.9	23.9	24.7	24.7	24.7
Oil Charge (3/4 of sightglass)	litre	1.6	1.6	1.6	1.6	1.6	1.6	1.6	1.6
Electrical data									
Motor version		2	1	3	2	1	2	2	1
Connections		1	1	1	1	1	1	1	1
MRA max operating current 230V / 50Hz	A	17.3	20.1	12.5	20.3	23.9	19.1	22.1	26.8
MRA max operating current 400V / 50Hz	A	10.0	11.6	7.2	11.7	13.8	11.0	12.7	15.4
Max power consumption	kW	5.7	6.6	4.0	6.8	7.9	7.0	8.5	8.4
LRA max starting current 230V / 50Hz - 280V / 60Hz DOL motor	A	92.6	109.7	97.8	92.6	109.7	92.6	109.7	151.8
LRA max starting current 400V / 50Hz - 460V / 60Hz DOL motor	A	53.2	63.1	56.3	53.2	63.1	53.2	63.1	87.3

Connections:

1 = 220-240V (Δ) - 380-420V (Y) / 3ph / 50Hz and 265-290V (Δ) - 440-480V (Y) / 3ph / 60Hz

2 = 380V-420V (Y/YY) / 3ph / 50Hz and 440V-480V (Y/YY) / 3ph / 60Hz

Tolerance ±10% based on mean value of voltage range. Other voltages upon request.

The indicated data refers to operation 50 Hz.

For 60Hz and other power supply voltage refer to FSS.3 selection software.

To select the contactors, cables and fuses, consider the maximum operating current and maximum input power.

Use AC3 Category contactors.

Compressor Model		Q5-28.1E	Q5-28.1Y	Q7-28.1Y	Q5-33.1E	Q5-33.1Y	Q7-33.1Y	Q5-36.1E	Q7-36.1Y
Cylinders		4	4	4	4	4	4	4	4
Displacement @ 50Hz	m ³ /h	28.0	28.0	28.0	32.7	32.7	32.7	35.9	35.9
Oil Charge (3/4 of sightglass)	litre	1.6	1.6	1.6	1.6	1.6	1.6	1.6	1.6
Electrical data									
Motor version		3	2	1	3	2	1	3	1
Connections		7	7	7	7	7	7	7	7
MRA max operating current 230V / 50Hz	A	13.7	24.3	30.7	16.2	25.0	34.7	20.5	33.6
MRA max operating current 400V / 50Hz	A	7.9	14.0	17.6	9.3	14.4	20.0	11.8	19.4
Max power consumption	kW	4.7	8.2	9.5	5.6	8.3	11.2	6.9	10.8
LRA max starting current 230V / 50Hz - 280V / 60Hz DOL motor	A	95.1	109.7	151.8	95.0	109.7	151.8	109.7	151.8
LRA max starting current 400V / 50Hz - 460V / 60Hz DOL motor	A	54.7	63.1	87.3	54.7	63.1	87.3	63.1	87.3

Compressor Model		S5-33Y	S7-33Y	S8-42E	S8-42Y	S12-42Y	S10-52E	S10-52Y	S15-52Y
Cylinders		4	4	4	4	4	4	4	4
Displacement @ 50Hz	m ³ /h	32.8	32.8	41.3	41.3	41.3	51.5	51.5	51.5
Oil Charge (3/4 of sightglass)	litre	2.9	2.9	2.9	2.9	2.9	2.9	2.9	2.9
Electrical data									
Motor version		2	1	3	2	1	3	2	1
Connections		2	2	2	2	2	2	2	2
MRA max operating current 400V / 50Hz	A	15.9	20.4	12.8	20.3	22.4	14.7	24.5	32.4
Max power consumption	kW	7.8	11.1	7.3	11.8	12.9	8.4	14.9	17.8
LRA max starting current 400V / 50Hz - 460V / 60Hz PWS motor - DOL connection	A	57.8	75.0	90.3	90.3	102.3	102.7	102.3	117.1
LRA max starting current 400V / 50Hz - 460V / 60Hz PWS motor	A	35.5	47.0	52.7	52.7	59.1	59.5	59.1	74.8

Connections:

1 = 220-240V (Δ) - 380-420V (Y) / 3ph / 50Hz and 265-290V (Δ) - 440-480V (Y) / 3ph / 60Hz

2 = 380V-420V (Y/YY) / 3ph / 50Hz and 440V-480V (Y/YY) / 3ph / 60Hz

Tolerance ±10% based on mean value of voltage range. Other voltages upon request.

The indicated data refers to operation 50 Hz.

For 60Hz and other power supply voltage refer to FSS.3 selection software.

To select the contactors, cables and fuses, consider the maximum operating current and maximum input power.

Use AC3 Category contactors.

Compressor Model		S12-56E	S15-56Y	S20-56Y	V15-59E	V15-59Y	V20-59Y	V15-71E	V15-71Y
Cylinders		4	4	4	4	4	4	4	4
Displacement @ 50Hz	m ³ /h	56.0	56.0	56.0	58.5	58.5	58.5	70.8	70.8
Oil Charge (3/4 of sightglass)	litre	2.9	2.9	2.9	4.0	4.0	4.0	4.0	4.0
Electrical data									
Motor version		3	2	1	3	2	1	3	2
Connections		2	2	2	2	2	2	2	2
MRA max operating current 400V / 50Hz	A	16.1	30.7	38.4	17.5	31.1	35.3	20.2	32.2
Max power consumption	kW	9.0	16.5	19.6	10.2	17.8	19.6	12.0	19.6
LRA max starting current 400V / 50Hz - 460V / 60Hz PWS motor - DOL connection	A	102.7	117.1	136.2	102.7	117.1	180.5	102.7	117.1
LRA max starting current 400V / 50Hz - 460V / 60Hz PWS motor	A	59.5	74.8	87.5	59.5	74.8	106.6	59.5	74.8

Compressor Model		V25-71Y	V20-84E	V20-84Y	V30-84Y	V25-93Y	V32-93Y	V25-103E	V25-103Y
Cylinders		4	4	4	4	4	4	4	4
Displacement @ 50Hz	m ³ /h	70.8	83.8	83.8	83.8	93.1	93.1	102.9	102.9
Oil Charge (3/4 of sightglass)	litre	4.0	4.0	4.0	4.0	4.0	4.0	4.0	4.0
Electrical data									
Motor version		1	3	2	1	2	1	3	2
Connections		2	2	2	2	2	2	2	2
MRA max operating current 400V / 50Hz	A	43.5	27.2	46.2	49.2	52.3	53.1	29.9	52.3
Max power consumption	kW	23.6	14.2	24.2	28.4	25.8	30.9	16.9	28.8
LRA max starting current 400V / 50Hz - 460V / 60Hz PWS motor - DOL connection	A	202.7	173.0	180.5	224.4	202.7	239.2	210.3	202.7
LRA max starting current 400V / 50Hz - 460V / 60Hz PWS motor	A	118.3	103.0	106.6	132.6	118.3	144.5	122.7	118.3

Connections:

1 = 220-240V (Δ) - 380-420V (Y) / 3ph / 50Hz and 265-290V (Δ) - 440-480V (Y) / 3ph / 60Hz

2 = 380V-420V (Y/YY) / 3ph / 50Hz and 440V-480V (Y/YY) / 3ph / 60Hz

Tolerance ±10% based on mean value of voltage range. Other voltages upon request.

The indicated data refers to operation 50 Hz.

For 60Hz and other power supply voltage refer to FSS.3 selection software.

To select the contactors, cables and fuses, consider the maximum operating current and maximum input power.

Use AC3 Category contactors.

Compressor Model		V35-103Y	Z25-106E	Z25-106Y	Z35-106Y	Z30-126E	Z30-126Y	Z40-126Y	Z40-140Y
Cylinders		4	6	6	6	6	6	6	6
Displacement @ 50Hz	m ³ /h	102.9	106.2	106.2	106.2	125.7	125.7	125.7	139.7
Oil Charge (3/4 of sightglass)	litre	4.0	3.7	3.7	3.7	7.2	7.2	7.2	7.2
Electrical data									
Motor version		1	3	2	1	3	2	1	2
Connections		2	2	2	2	2	2	2	2
MRA max operating current 400V / 50Hz	A	61.0	30.2	53.6	60.2	33.8	55.7	71.9	70.0
Max power consumption	kW	38.5	17.1	31.9	35.1	19.7	35.0	40.7	37.9
LRA max starting current 400V / 50Hz - 460V / 60Hz PWS motor - DOL connection	A	239.2	210.3	202.7	239.2	212.5	224.4	273.0	273
LRA max starting current 400V / 50Hz - 460V / 60Hz PWS motor	A	144.5	122.7	118.3	144.5	122.7	132.6	159.2	159.2

Compressor Model		Z50-140Y	Z40-154E	Z40-154Y	Z50-154Y				
Cylinders		6	6	6	6				
Displacement @ 50Hz	m ³ /h	139.7	154.4	154.4	154.4				
Oil Charge (3/4 of sightglass)	litre	7.2	7.2	7.2	7.2				
Electrical data									
Motor version		1	3	2	1				
Connections		2	2	2	2				
MRA max operating current 400V / 50Hz	A	79.5	41.1	77.9	90.4				
Max power consumption	kW	52.1	23.8	37.9	52.1				
LRA max starting current 400V / 50Hz - 460V / 60Hz PWS motor - DOL connection	A	321.4	239.2	273.0	321.4				
LRA max starting current 400V / 50Hz - 460V / 60Hz PWS motor	A	188.6	144.5	159.2	188.8				

Connections:

1 = 220-240V (Δ) - 380-420V (Y) / 3ph / 50Hz and 265-290V (Δ) - 440-480V (Y) / 3ph / 60Hz

2 = 380V-420V (Y/YY) / 3ph / 50Hz and 440V-480V (Y/YY) / 3ph / 60Hz

Tolerance ±10% based on mean value of voltage range. Other voltages upon request.

The indicated data refers to operation 50 Hz.

For 60Hz and other power supply voltage refer to FSS.3 selection software.

To select the contactors, cables and fuses, consider the maximum operating current and maximum input power.

Use AC3 Category contactors.

Compressor Model		W40-142Y	W40-168Y	W50-168Y	W50-187Y	W60-187Y	W60-206Y		
Cylinders		8	8	8	8	8	8		
Displacement @ 50Hz	m ³ /h	141.5	167.6	167.6	186.1	186.1	205.8		
Oil Charge (3/4 of sightglass)	litre	7.7	7.7	7.7	7.7	7.7	7.7		
Electrical data									
Motor version		2	2	1	2	1	2		
Connections		2	2	2	2	2	2		
MRA max operating current 400V / 50Hz	A	89.3	71.4	94.8	89.1	103.5	98.8		
Max power consumption	kW	42.3	37.3	55.2	50.2	59.9	56.7		
LRA max starting current 400V / 50Hz - 460V / 60Hz PWS motor - DOL connection	A	298.0	298.0	367.0	367.0	455.0	202.7		
LRA max starting current 400V / 50Hz - 460V / 60Hz PWS motor	A	215.0	215.0	258.0	258.0	326.0	118.3		

Compressor Model		W70-206Y	W70-228Y	W75-228Y	W75-240Y	W80-240Y			
Cylinders		8	8	8	8	8			
Displacement @ 50Hz	m ³ /h	205.8	227.8	227.8	239.0	239.0			
Oil Charge (3/4 of sightglass)	litre	7.7	7.7	7.7	7.7	7.7			
Electrical data									
Motor version		1	2	1	2	1			
Connections		2	2	2	2	2			
MRA max operating current 400V / 50Hz	A	116.8	109.5	128.4	115.3	135.7			
Max power consumption	kW	66.8	61.9	74.2	65.4	78.9			
LRA max starting current 400V / 50Hz - 460V / 60Hz PWS motor - DOL connection	A	548.0	548.0	584.0	584.0	584.0			
LRA max starting current 400V / 50Hz - 460V / 60Hz PWS motor	A	390.0	390.0	417.0	417.0	417.0			

Connections:

1 = 220-240V (Δ) - 380-420V (Y) / 3ph / 50Hz and 265-290V (Δ) - 440-480V (Y) / 3ph / 60Hz

2 = 380V-420V (Y/YY) / 3ph / 50Hz and 440V-480V (Y/YY) / 3ph / 60Hz

Tolerance ±10% based on mean value of voltage range. Other voltages upon request.

The indicated data refers to operation 50 Hz.

For 60Hz and other power supply voltage refer to FSS.3 selection software.

To select the contactors, cables and fuses, consider the maximum operating current and maximum input power.

Use AC3 Category contactors.

R134a Operating Limits

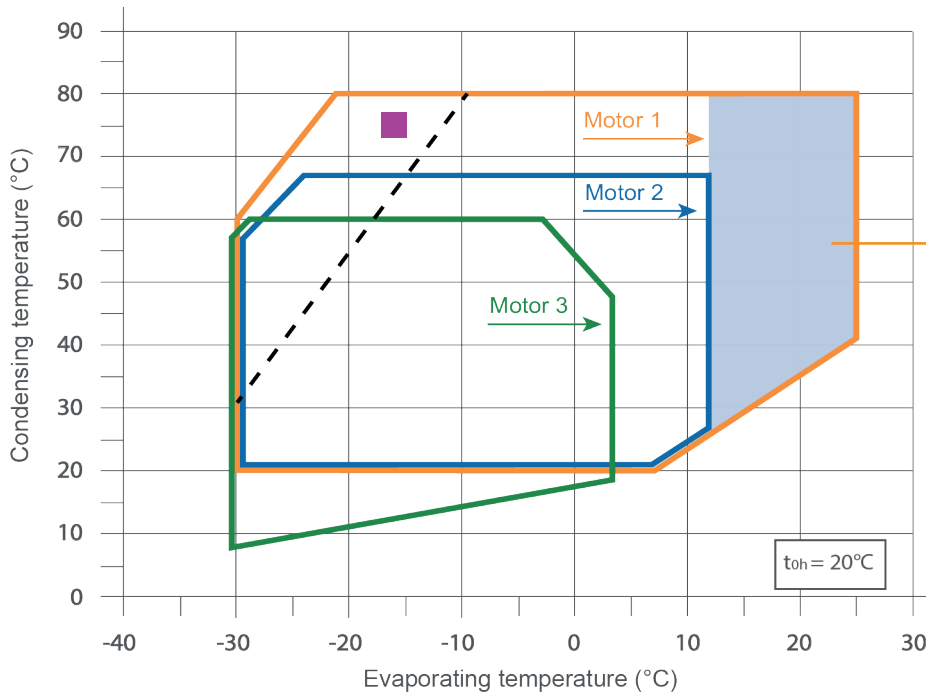

Standard application diagram

Motor size 1 - 2 - 3
Compressor capacity 100%
Suction gas temperature 20°C

For operation in this area please contact Frascold

R450A - R513A Operating Limits

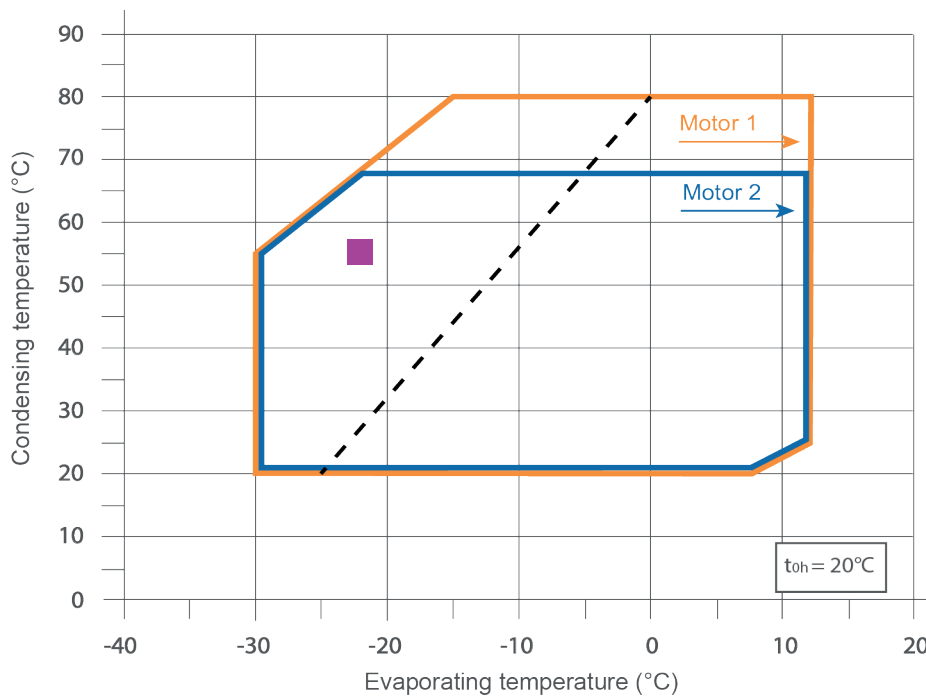

Standard application diagram

Motor size 1 - 2
Compressor capacity 100%
Suction gas temperature 20°C

■ For additional cooling or superheat reduction. or for performance data on a specific compressor model, please refer to Frascold selection software FSS.3

R404A - R507A Operating Limits

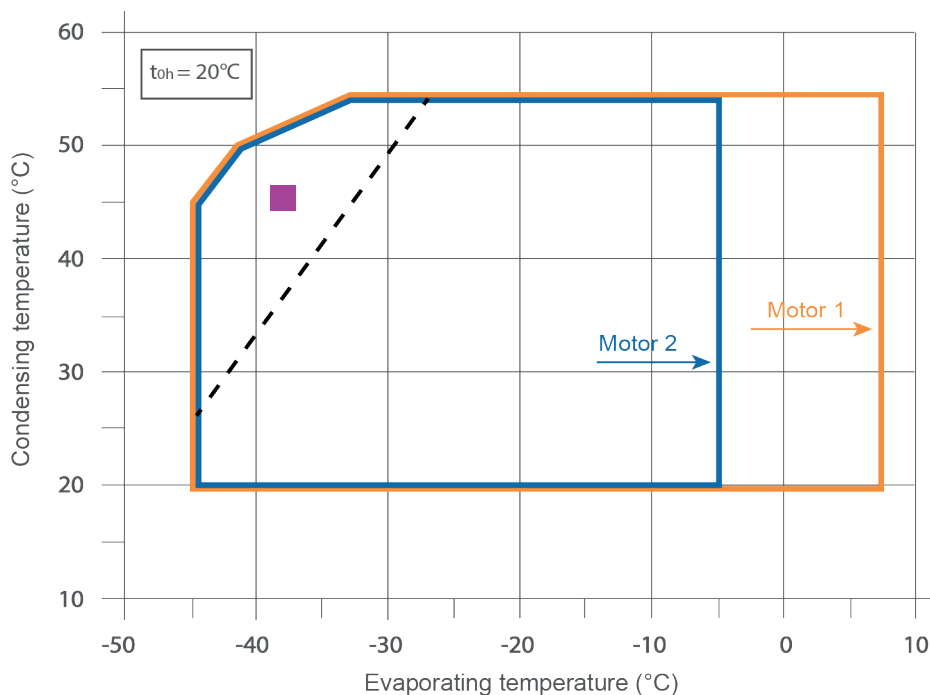

Standard application diagram

Motor size 1 - 2
 Compressor capacity 100%
 Suction gas temperature 20°C

R448A - R449A Operating Limits

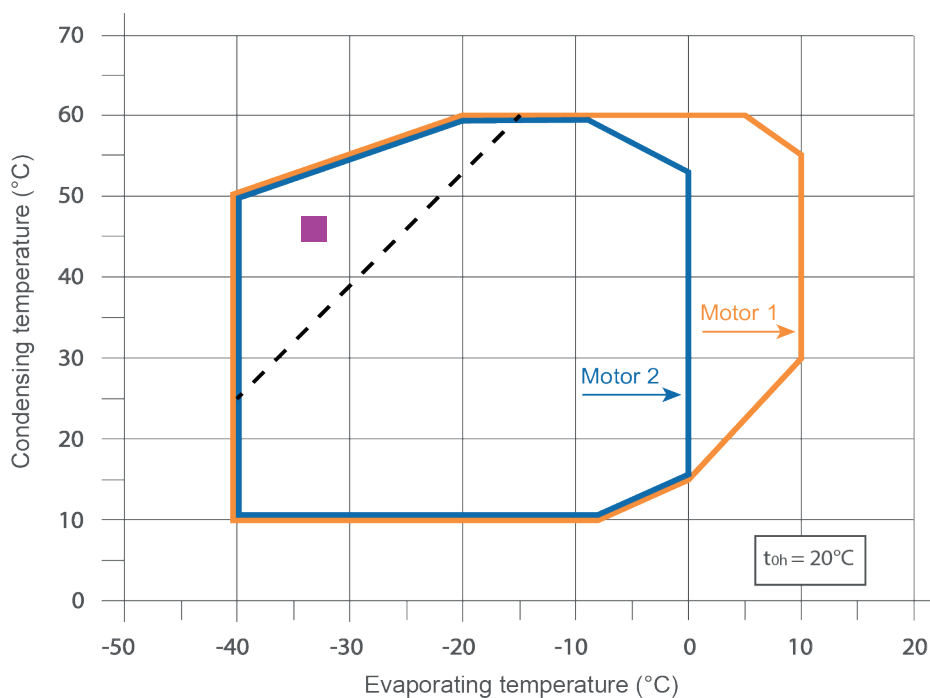

Standard application diagram

Motor size 1 - 2
 Compressor capacity 100%
 Suction gas temperature 20°C

■ For additional cooling or superheat reduction, or for performance data on a specific compressor model, please refer to Frascold selection software FSS.3

R407F - R407A Operating Limits

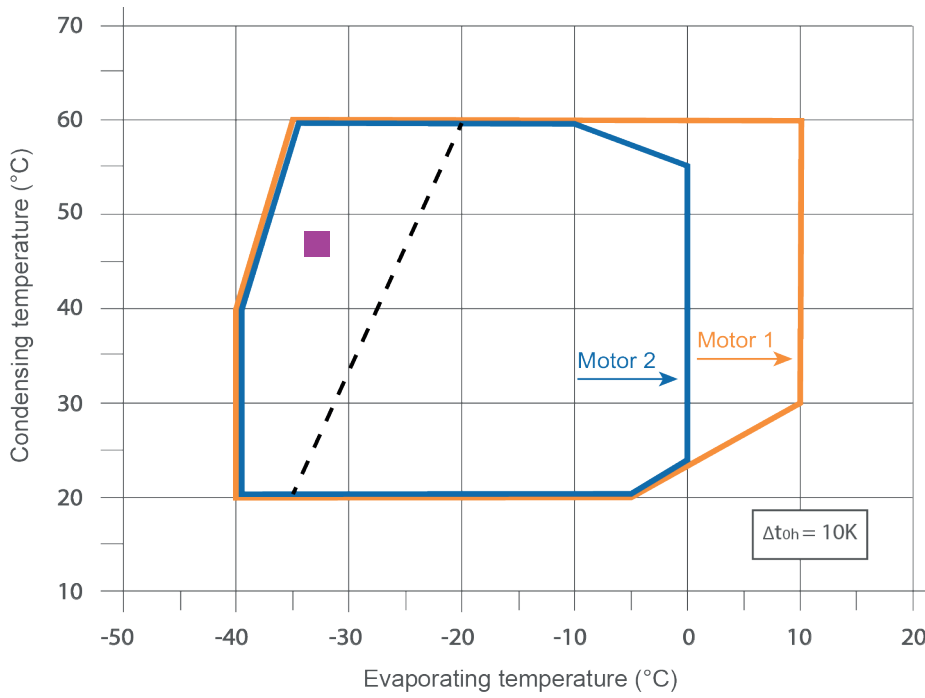

Standard application diagram

Motor size 1 - 2
Compressor capacity 100%
Suction gas temperature 20°C

R407C Operating Limits

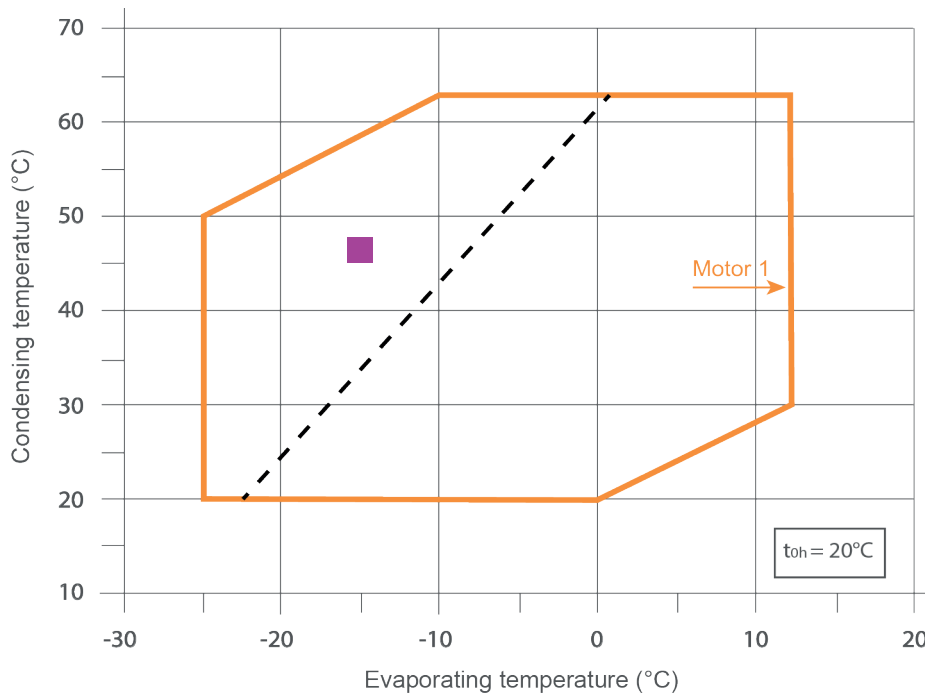

Standard application diagram

Motor size 1
Compressor capacity 100%
Suction gas temperature 20°C

■ For additional cooling or superheat reduction, or for performance data on a specific compressor model, please refer to Frascold selection software FSS.3

R1234ze Operating Limits

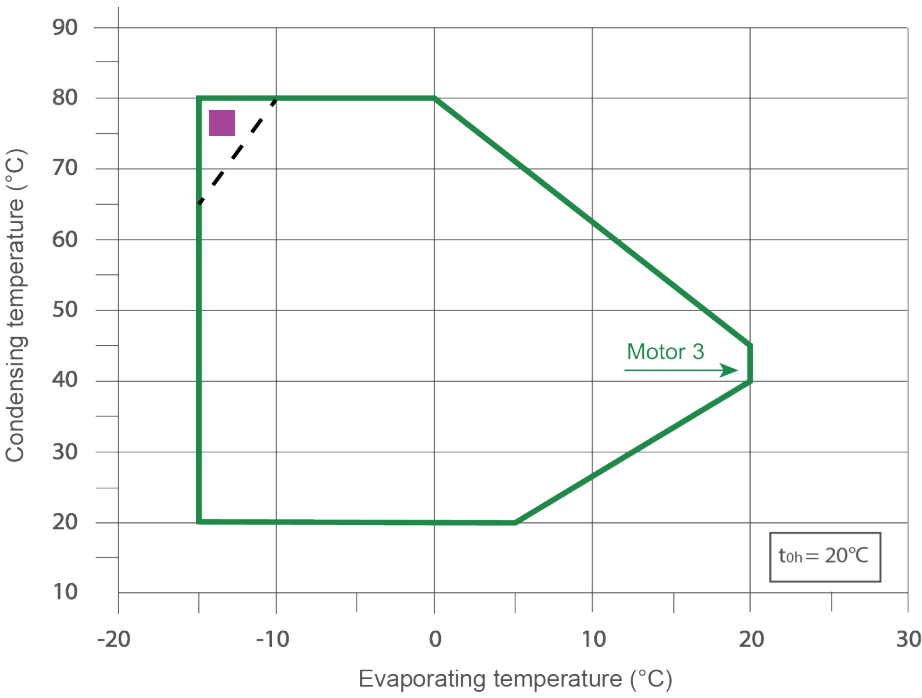

Standard application diagram

Motor size 3
Compressor capacity 100%
Suction gas temperature 20° C

R22 Operating Limits

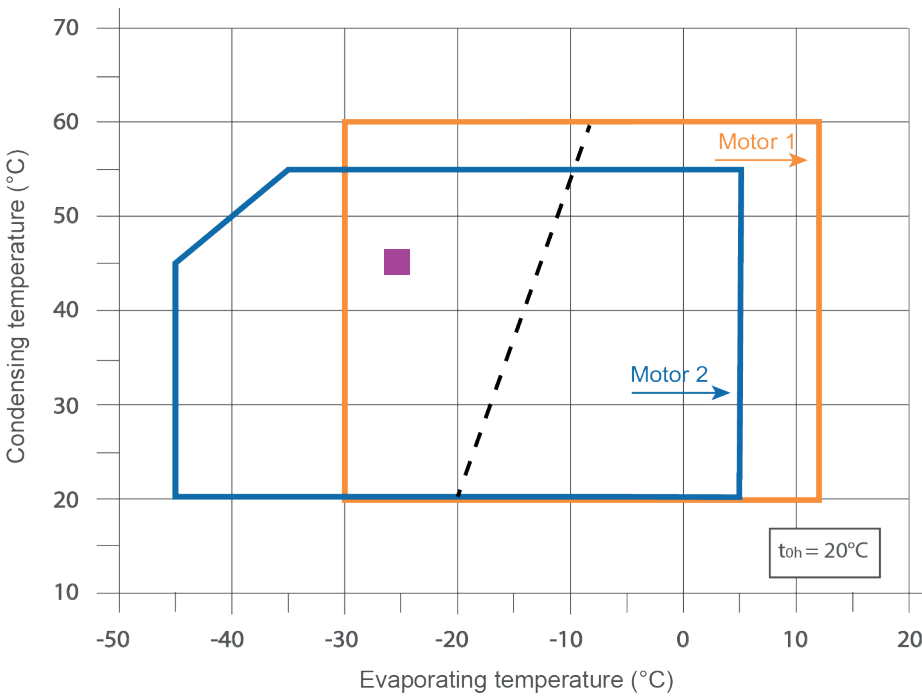

Standard application diagram

Motor size 1 - 2
Compressor capacity 100%
Suction gas temp 20° C

■ For additional cooling or superheat reduction. or for performance data on a specific compressor model, please refer to Frascold selection software FSS.3

Dimensional Drawing Series A

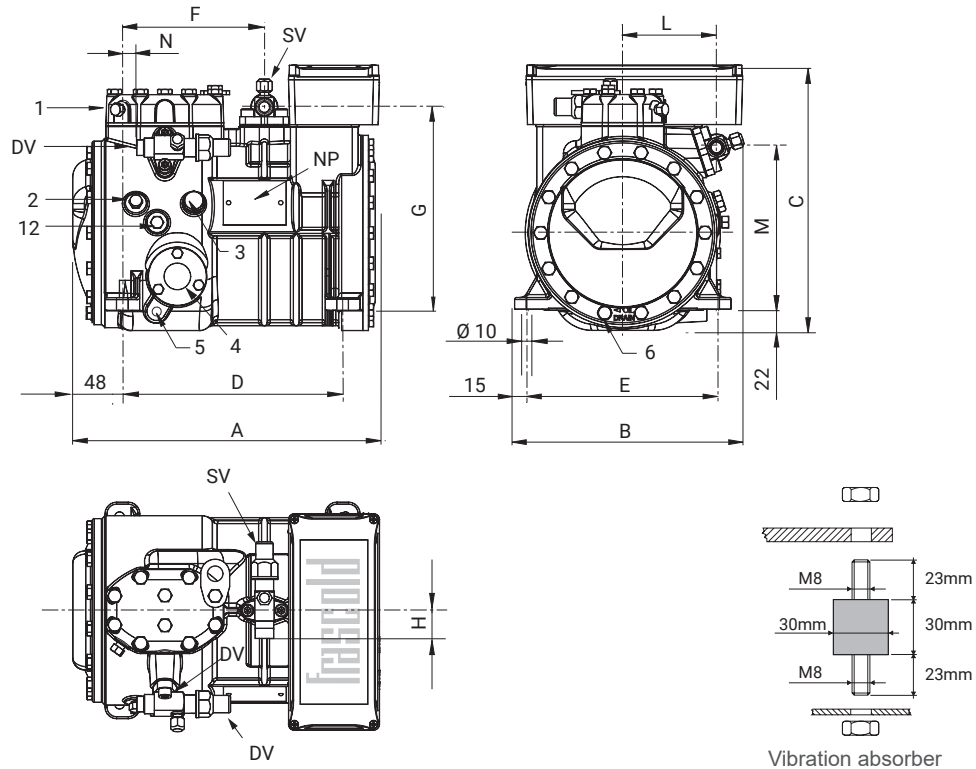

1	High pressure plug	1/8" NPT
2	Low pressure plug	1/8" NPT
3	Oil charge plug	1/4" GAS
4	Oil level sight glass	
5	Crankcase heater socket	
6	Oil drain plug	M8 x 22
12	Oil return plug	1/8" NPT
DV	Discharge valve	
SV	Suction valve	
NP	Nameplate	

Compressor	Compressor					Valves position						Valves				Net Weight
	Length	Width	Height	Base mounting		Suction			Discharge			Suction		Discharge		
	A	B	C	D	E	F	G	H	L	M	N	Ø	Ø	Ø	Ø	
	mm	mm	mm	mm	mm	mm	mm	mm	mm	mm	mm	inch	mm	inch	mm	kg
A05-4Y	317	237	275	234	194	150	209	29	97	167	18	5/8	15.8	1/2	12.7	36
A05-5Y	317	237	275	234	194	150	209	29	97	167	18	5/8	15.8	1/2	12.7	36
A07-5Y	317	237	275	234	194	150	209	29	97	167	18	5/8	15.8	1/2	12.7	36
A07-6Y	317	237	275	234	194	150	209	29	97	167	18	5/8	15.8	1/2	12.7	36
A1-6Y	317	237	275	234	194	150	209	29	97	167	18	5/8	15.8	1/2	12.7	36
A1-7Y	317	237	275	234	194	150	209	29	97	167	18	5/8	15.8	1/2	12.7	36
A1.5-7Y	317	237	275	234	194	150	209	29	97	167	18	5/8	15.8	1/2	12.7	36
A1.5-8Y	317	237	275	234	194	150	209	29	97	167	18	5/8	15.8	1/2	12.7	36

Dimensional Drawing Series B

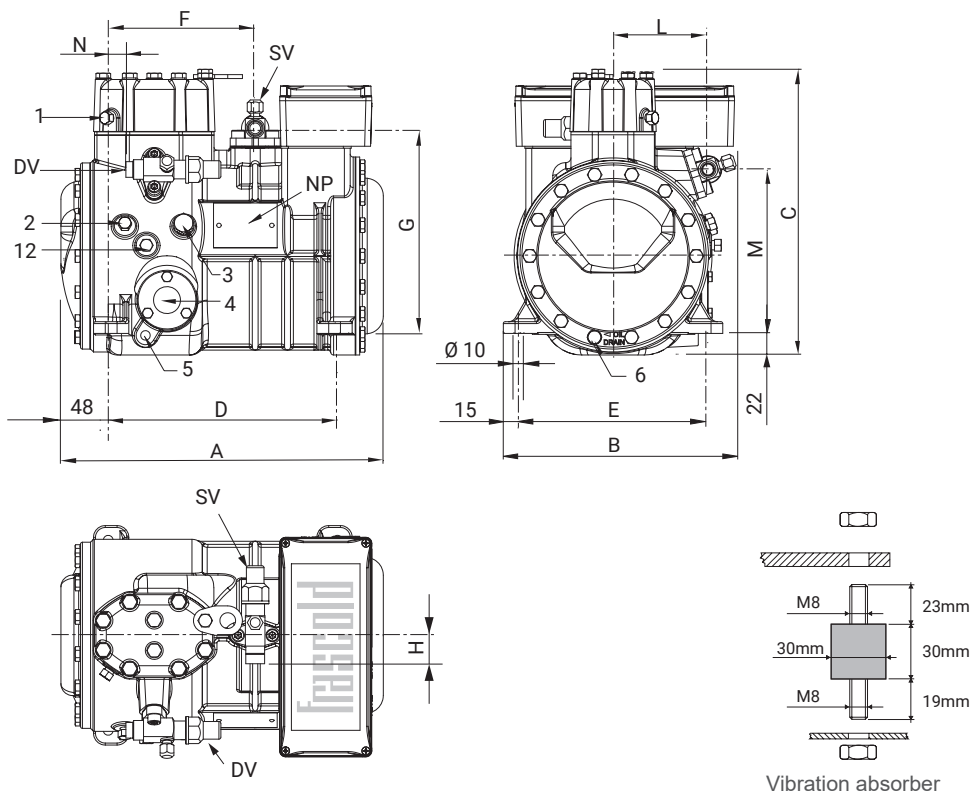

1	High pressure plug	1/8" NPT
2	Low pressure plug	1/8" NPT
3	Oil charge plug	1/4" GAS
4	Oil level sight glass	
5	Crankcase heater socket	
6	Oil drain plug	M8 x 22
12	Oil return plug	1/8" NPT
DV	Discharge valve	
SV	Suction valve	
NP	Nameplate	

Compressor	Compressor					Valves position						Valves				Net Weight
	Length	Width	Height	Base mounting		Suction			Discharge			Suction		Discharge		
	A	B	C	D	E	F	G	H	L	M	N	Ø	Ø	Ø	Ø	
B1.5-9.1Y	329	237	292	234	194	150	209	29	97	167	18	5/8	15.8	1/2	12.7	38
B1.5-10.1Y	329	237	292	234	194	150	209	29	97	167	18	5/8	15.8	1/2	12.7	38
B2-10.1Y	334	237	292	234	194	150	209	31	97	167	18	3/4	19.0	5/8	15.8	40

Dimensional Drawing Series D

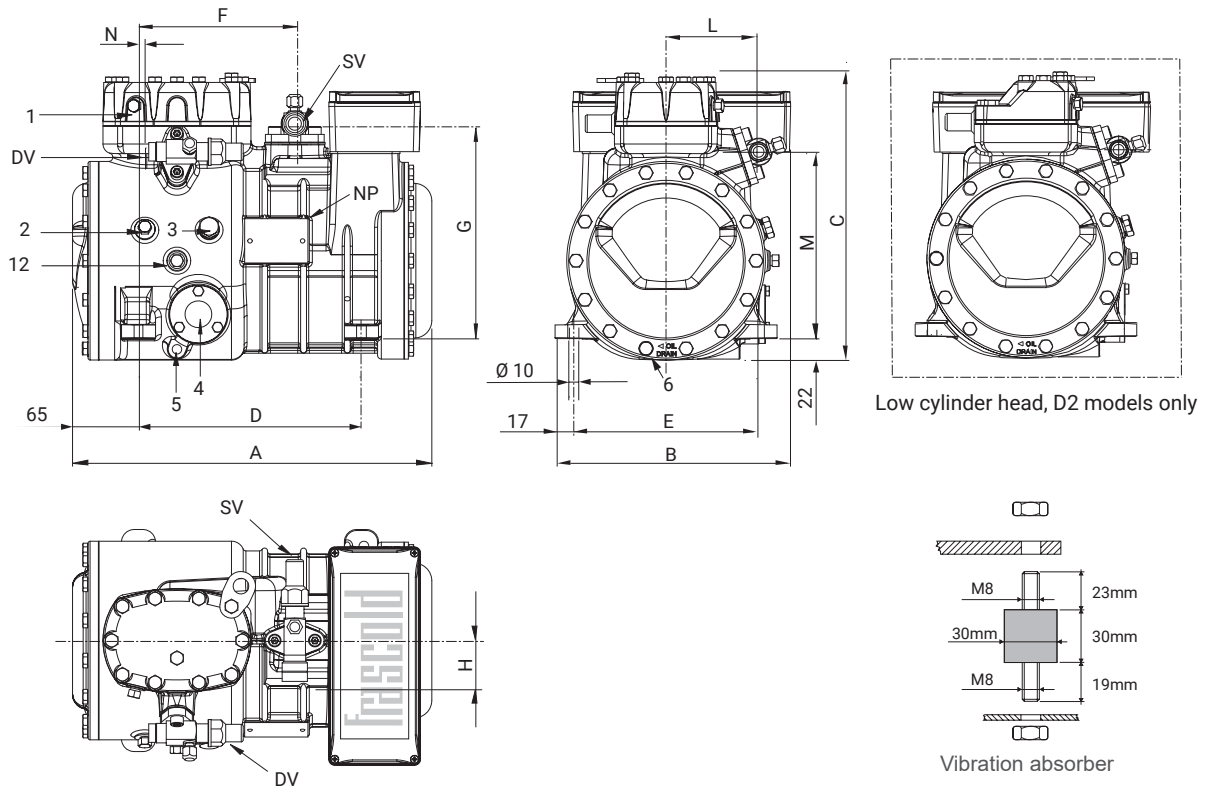

1	High pressure plug	1/8" NPT
2	Low pressure plug	1/8" NPT
3	Oil charge plug	1/4" GAS
4	Oil level sight glass	
5	Crankcase heater socket	
6	Oil drain plug	M8 x 22
12	Oil return plug	1/8" NPT
DV	Discharge valve	
SV	Suction valve	
NP	Nameplate	

Compressor	Compressor					Valves position						Valves				Net Weight
	Length	Width	Height	Base mounting		Suction			Discharge			Suction		Discharge		
	A	B	C	D	E	F	G	H	L	M	N	Ø	Ø	Ø	Ø	
	mm	mm	mm	mm	mm	mm	mm	mm	mm	mm	mm	inch	mm	inch	mm	kg
D2-11.1Y*	369	242	294	234	194	165	221	42	94	192	13	7/8	22.2	5/8	15.8	45
D2-13.1Y*	369	242	294	234	194	165	221	42	94	192	13	7/8	22.2	5/8	15.8	45
D3-13.1Y	374	242	317	234	194	165	225	53	94	192	13	1 1/8	28.6	5/8	15.8	49
D2-15.1Y*	369	242	294	234	194	165	221	42	94	192	13	7/8	22.2	5/8	15.8	45
D3-15.1Y	374	242	317	234	194	165	225	53	94	192	13	1 1/8	28.6	5/8	15.8	49
D3-16.1Y	374	242	317	234	194	165	225	53	94	192	13	1 1/8	28.6	5/8	15.8	49
D4-16.1Y	401	242	317	234	194	165	225	53	94	192	5	1 1/8	28.6	3/4	19.0	51
D3-18.1Y	374	242	317	234	194	165	225	53	94	192	13	1 1/8	28.6	5/8	15.8	49
D4-18.1Y	401	242	317	234	194	165	225	53	94	192	5	1 1/8	28.6	3/4	19.0	51
D3-19.1Y	374	242	317	234	194	165	225	53	94	192	13	1 1/8	28.6	5/8	15.8	49
D4-19.1Y	401	242	317	234	194	165	225	53	94	192	5	1 1/8	28.6	3/4	19.0	51

Dimensional Drawing Series Q

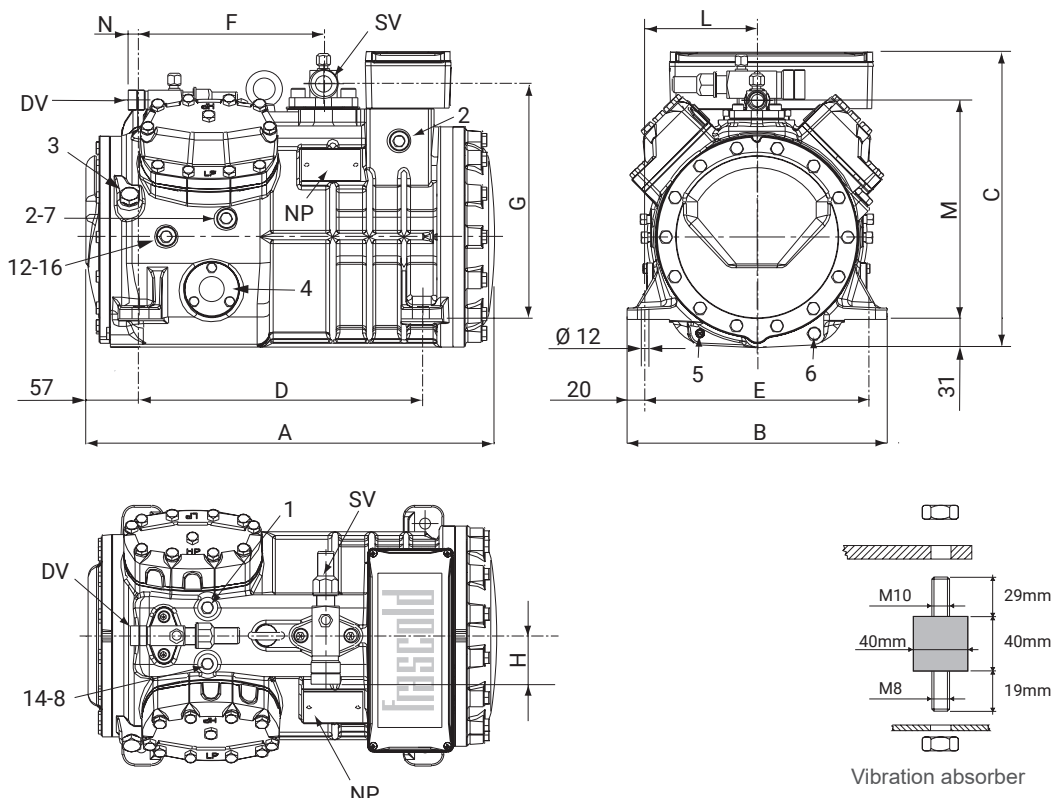

1	High pressure plug	1/8" NPT
2	Low pressure plug	1/8" NPT
3	Oil charge plug	1/4" GAS
4	Oil level sight glass	
5	Crankcase heater socket	
6	Oil drain plug	M8 x 22
7	Liquid injection valve plug	1/8" NPT
8	Liquid injection sensor plug	1/8" NPT
12	Oil return plug	1/8" NPT
14	Max. discharge temperature sensor	1/8" NPT
16	Crankcase pressure plug	1/8" NPT
DV	Discharge valve	
SV	Suction valve	
NP	Nameplate	

Compressor	Compressor				Valves position							Valves				Net Weight
	Length	Width	Height	Base mounting	Suction			Discharge				Suction		Discharge		
	A	B	C	D	E	F	G	H	L	M	N	Ø	Ø	Ø	Ø	
Q4-20.1E	449	286	325	312	246	203	258	53	123	239	12	1 1/8	28.6	3/4	19.0	74
Q4-20.1Y	449	286	325	312	246	203	258	53	123	239	12	1 1/8	28.6	3/4	19.0	74
Q4-21.1Y	449	286	325	312	246	203	258	53	123	239	12	1 1/8	28.6	3/4	19.0	79
Q5-21.1Y	449	286	325	312	246	203	258	53	123	239	12	1 1/8	28.6	3/4	19.0	79
Q4-24.1E	449	286	325	312	246	203	258	53	123	239	12	1 1/8	28.6	3/4	19.0	79
Q4-24.1Y	449	286	325	312	246	203	258	53	123	239	12	1 1/8	28.6	3/4	19.0	79
Q5-24.1Y	449	286	325	312	246	203	258	53	123	239	17	1 1/8	28.6	7/8	22.2	79
Q4-25.1Y	449	286	325	312	246	203	258	53	123	239	17	1 1/8	28.6	3/4	19.0	77
Q5-25.1Y	449	286	325	312	246	203	258	53	123	239	17	1 1/8	28.6	7/8	22.2	79
Q7-25.1Y	449	286	325	312	246	203	258	53	123	239	17	1 1/8	28.6	7/8	22.2	79
Q5-28.1E	449	286	328	312	246	203	261	58	123	239	17	1 3/8	35.0	7/8	22.2	79
Q5-28.1Y	449	286	325	312	246	203	261	58	123	239	17	1 3/8	35.0	7/8	22.2	79
Q7-28.1Y	449	286	328	312	246	203	261	58	123	239	28	1 3/8	35.0	1 1/8	28.6	79
Q5-33.1E	449	286	328	312	246	203	261	58	123	239	28	1 3/8	35.0	1 1/8	28.6	79
Q5-33.1Y	449	286	328	312	246	203	261	58	123	239	28	1 3/8	35.0	1 1/8	28.6	79
Q7-33.1Y	449	286	328	312	246	203	261	58	123	239	28	1 3/8	35.0	1 1/8	28.6	79
Q5-36.1Y	449	286	328	312	246	203	261	58	123	239	28	1 3/8	35.0	1 3/8	28.6	79
Q7-36.1Y	449	286	328	312	246	203	261	58	123	239	28	1 3/8	35.0	1 3/8	28.6	79

Dimensional Drawing Series S

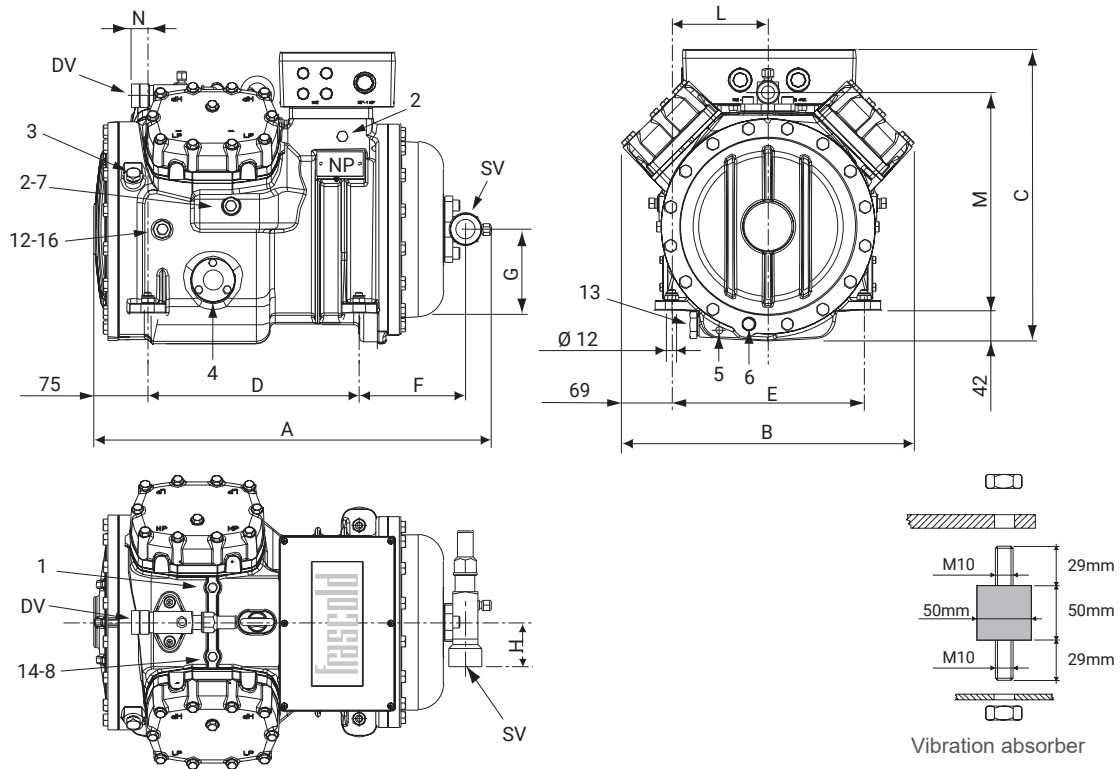

1	High pressure plug	1/8" NPT
2	Low pressure plug	1/8" NPT
3	Oil charge plug	1/4" GAS
4	Oil level sight glass	
5	Crankcase heater socket	
6	Oil drain plug	M10 x 30
7	Liquid injection valve plug	1/4" NPT
8	Liquid injection sensor plug	1/8" NPT
12	Oil return plug	1/4" NPT
13	Magnetic plug	1/2" GAS
14	Max discharge temperature sensor	1/8" NPT
16	Crankcase pressure plug	1/4" NPT
DV	Discharge valve	
SV	Suction valve	
NP	Nameplate	

Compressor	Compressor					Valves position						Valves				Net Weight
	Length	Width	Height	Base mounting		Suction		Discharge				Suction		Discharge		
	A	B	C	D	E	F	G	H	L	M	N	Ø	Ø	Ø	Ø	
	mm	mm	mm	mm	mm	mm	mm	mm	mm	mm	mm	inch	mm	inch	mm	kg
S5-33Y	550	405	405	292	266	147	115	58	133	298	23	1 3/8	35.0	1 1/8	28.6	115
S7-33Y	550	405	405	292	266	147	115	58	133	298	23	1 3/8	35.0	1 1/8	28.6	117
S8-42E	550	405	405	292	266	147	115	58	133	298	23	1 3/8	35.0	1 1/8	28.6	117
S8-42Y	550	405	405	292	266	147	115	58	133	298	23	1 3/8	35.0	1 1/8	28.6	117
S12-42Y	550	405	405	292	266	147	115	58	133	298	23	1 3/8	35.0	1 1/8	28.6	120
S10-52E	550	405	405	292	266	147	115	58	133	298	23	1 3/8	35.0	1 1/8	28.6	120
S10-52Y	550	405	405	292	266	147	115	58	133	298	23	1 3/8	35.0	1 1/8	28.6	120
S15-52Y	550	405	405	292	266	147	115	61	133	298	23	1 5/8	42.0	1 1/8	28.6	126
S12-56E	550	405	405	292	266	147	115	58	133	298	23	1 3/8	35.0	1 1/8	28.6	130
S15-56Y	550	405	405	292	266	147	115	61	133	298	23	1 5/8	42.0	1 1/8	28.6	130
S20-56Y	550	405	405	292	266	147	115	61	133	298	23	1 5/8	42.0	1 1/8	28.6	132

Dimensional Drawing Series V

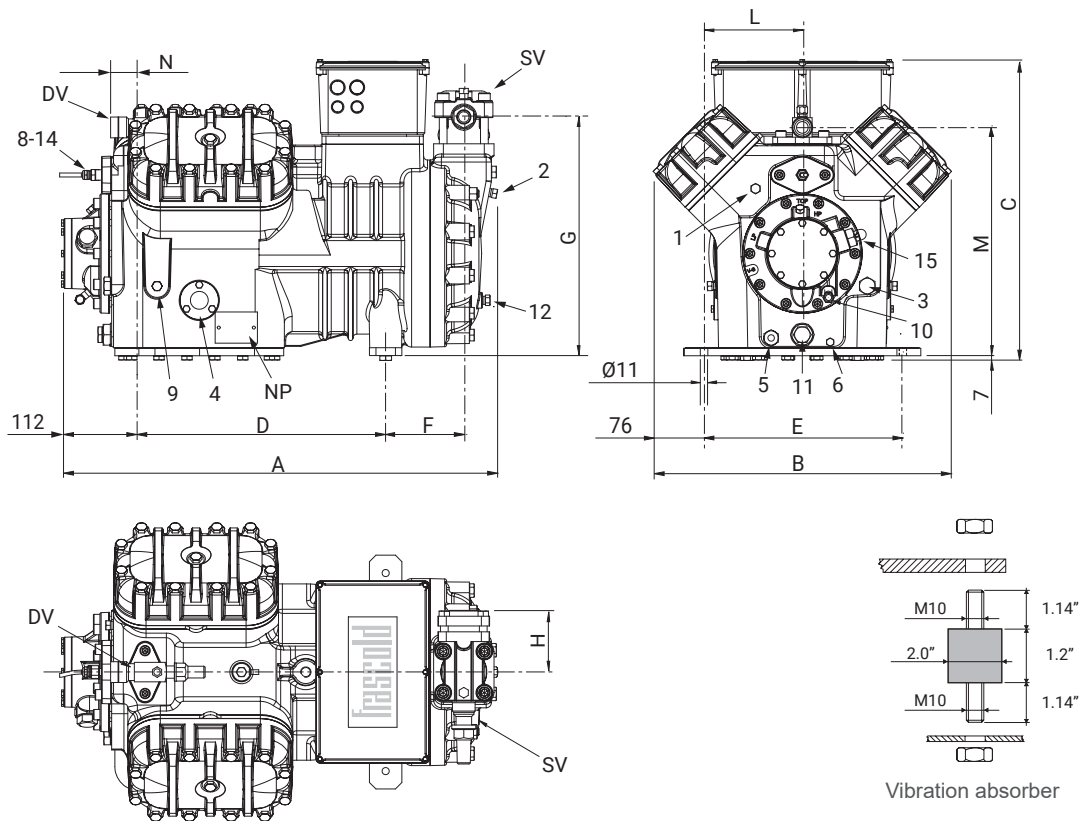

1	High pressure plug	1/8" NPT
2	Low pressure plug	1/4" NPT
3	Oil charge plug	3/8" GAS
4	Oil level sight glass	
5	Crankcase heater socket	
6	Oil drain plug	3/8" GAS
7	Liquid injection valve plug	1/8" NPT
8	Liquid injection sensor plug	1/8" NPT
9	Oil pressure switch connection (LP)	1/4" NPT
10	Oil pressure switch connection (HP)	1/4" SAE
11	Oil filter	3/8" GAS
12	Oil return plug	1/4" NPT
14	Max discharge temperature sensor	
15	Electronic oil pressure switch connection	3/4" UNF
DV	Discharge valve	
SV	Suction valve	
NP	Nameplate	

Compressor	Compressor					Valves position						Valves				Net Weight
	Length	Width	Height	Base mounting		Suction			Discharge			Suction		Discharge		
				A	B	C	D	E	F	G	H	L	M	N	Ø	
V15-59E	672	460	463	381	305	120	367	95	152	352	43	1 5/8	42.0	1 1/8	28.6	170
V15-59Y	672	460	463	381	305	120	367	95	152	352	43	1 5/8	42.0	1 1/8	28.6	170
V20-59Y	672	460	463	381	305	120	367	95	152	352	43	1 5/8	42.0	1 1/8	28.6	174
V15-71E	672	460	463	381	305	120	367	95	152	352	43	1 5/8	42.0	1 1/8	28.6	174
V15-71Y	672	460	463	381	305	120	367	95	152	352	43	1 5/8	42.0	1 1/8	28.6	174
V25-71Y	703	460	463	381	305	133	389	130	152	352	48	2 1/8	54.0	1 1/8	35.0	184
V20-84E	703	460	463	381	305	133	389	130	152	352	48	2 1/8	54.0	1 1/8	28.6	180
V20-84Y	672	460	463	381	305	120	367	95	152	352	43	1 5/8	42.0	1 1/8	28.6	180
V30-84Y	703	460	463	381	305	133	389	130	152	352	48	2 1/8	54.0	1 3/8	35.0	187
V25-93Y	703	460	463	381	305	133	389	130	152	352	48	2 1/8	54.0	1 3/8	35.0	200
V32-93Y	743	460	463	381	305	158	389	130	152	352	48	2 1/8	54.0	1 3/8	35.0	192
V25-103Y	703	460	463	381	305	133	389	130	152	352	48	2 1/8	54.0	1 3/8	35.0	204
V35-103Y	743	460	463	381	305	158	389	130	152	352	48	2 1/8	54.0	1 3/8	35.0	204
V25-103E	703	460	463	381	305	133	389	130	152	352	48	2 1/8	54.0	1 3/8	35.0	207

Dimensional Drawing Series Z

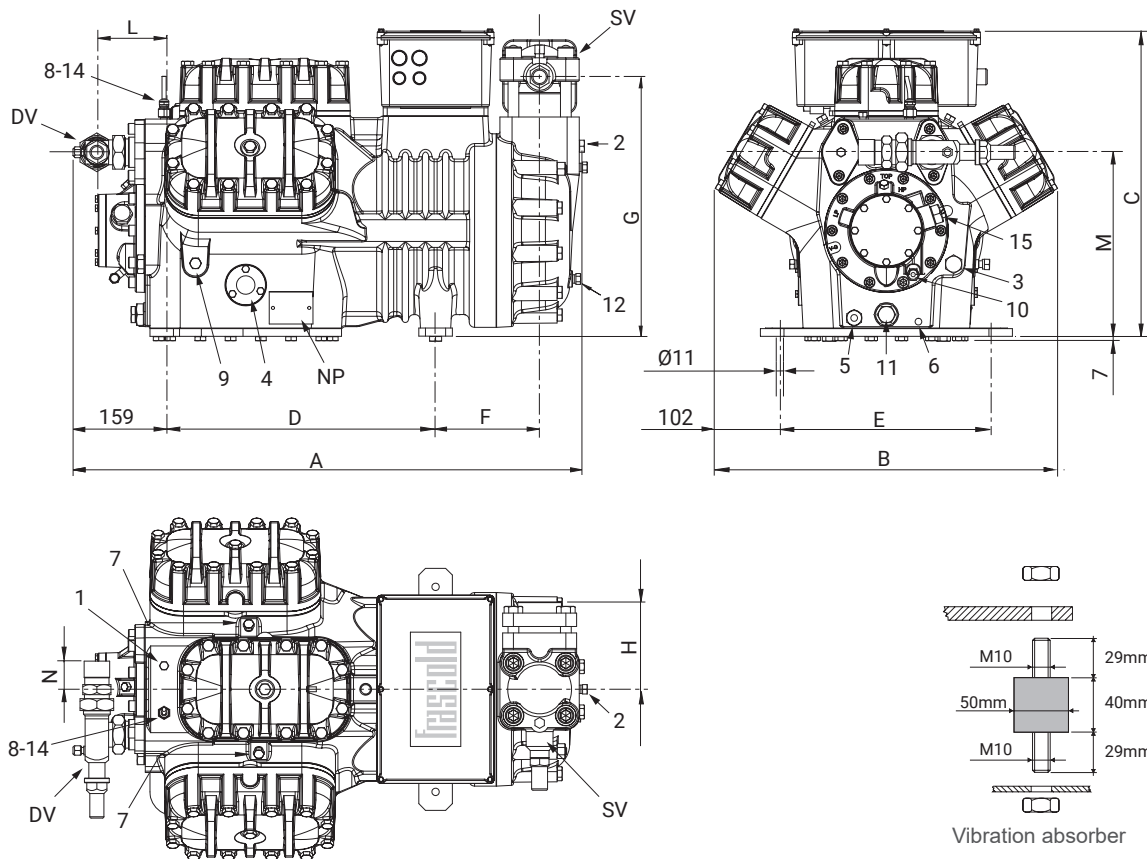

1	High pressure plug	1/8" NPT
2	Low pressure plug	1/4" NPT
3	Oil charge plug	3/8" GAS
4	Oil level sight glass	
5	Crankcase heater socket	
6	Oil drain plug	3/8" GAS
7	Liquid injection valve plug	1/8" NPT
8	Liquid injection sensor plug	1/8" NPT
9	Oil pressure switch connection (LP)	1/4" NPT
10	Oil pressure switch connection (HP)	1/4" SAE
11	Oil filter	3/8" GAS
12	Oil return plug	1/4" NPT
14	Max discharge temperature sensor	1/8" NPT
15	Electronic oil pressure switch connection	3/4" UNF
DV	Discharge valve	
SV	Suction valve	
NP	Nameplate	

Compressor	Compressor				Valves position							Valves				Net Weight
	Length	Width	Height	Base mounting	Suction			Discharge				Suction		Discharge		
	A	B	C	D	E	F	G	H	L	M	N	Ø	Ø	Ø	Ø	
Z25-106E	765	509	457	381	305	155	386	130	123	274	42	2 1/8	54.0	1 3/8	35.0	220
Z25-106Y	765	509	457	381	305	155	386	130	123	274	42	2 1/8	54.0	1 3/8	35.0	220
Z35-106Y	806	509	457	381	305	180	386	130	123	274	42	2 1/8	54.0	1 3/8	35.0	223

Dimensional Drawing Series Z

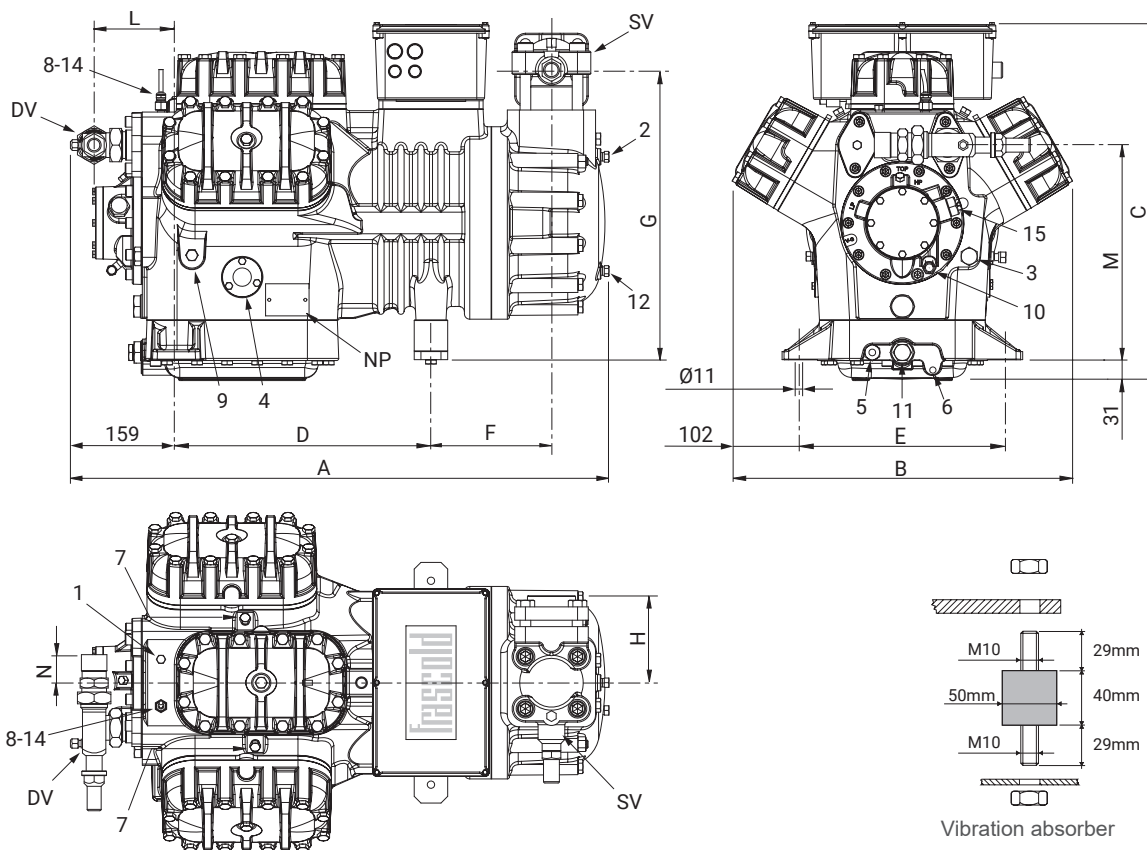

1	High pressure plug	1/8" NPT
2	Low pressure plug	1/4" NPT
3	Oil charge plug	3/8" GAS
4	Oil level sight glass	
5	Crankcase heater socket	
6	Oil drain plug	3/8" GAS
7	Liquid injection valve plug	1/8" NPT
8	Liquid injection sensor plug	1/8" NPT
9	Oil pressure switch connection (LP)	1/4" NPT
10	Oil pressure switch connection (HP)	1/4" SAE
11	Oil filter	3/8" GAS
12	Oil return plug	1/4" NPT
14	Max discharge temperature sensor	1/8" NPT
15	Electronic oil pressure switch connection	3/4" UNF
DV	Discharge valve	
SV	Suction valve	
NP	Nameplate	

Compressor	Compressor				Valves position							Valves				Net Weight
	Length	Width	Height	Base mounting	Suction			Discharge				Suction		Discharge		
	A	B	C	D	E	F	G	H	L	M	N	Ø	Ø	Ø	Ø	
Z30-126E	765	509	536	381	305	155	433	130	123	321	42	2 1/8	54.0	1 3/8	35.0	229
Z30-126Y	765	509	536	381	305	155	433	130	123	321	42	2 1/8	54.0	1 3/8	35.0	229
Z40-126Y	806	509	536	381	305	180	433	130	123	321	42	2 5/8	67.0	1 5/8	42.0	240

Dimensional Drawing Series Z

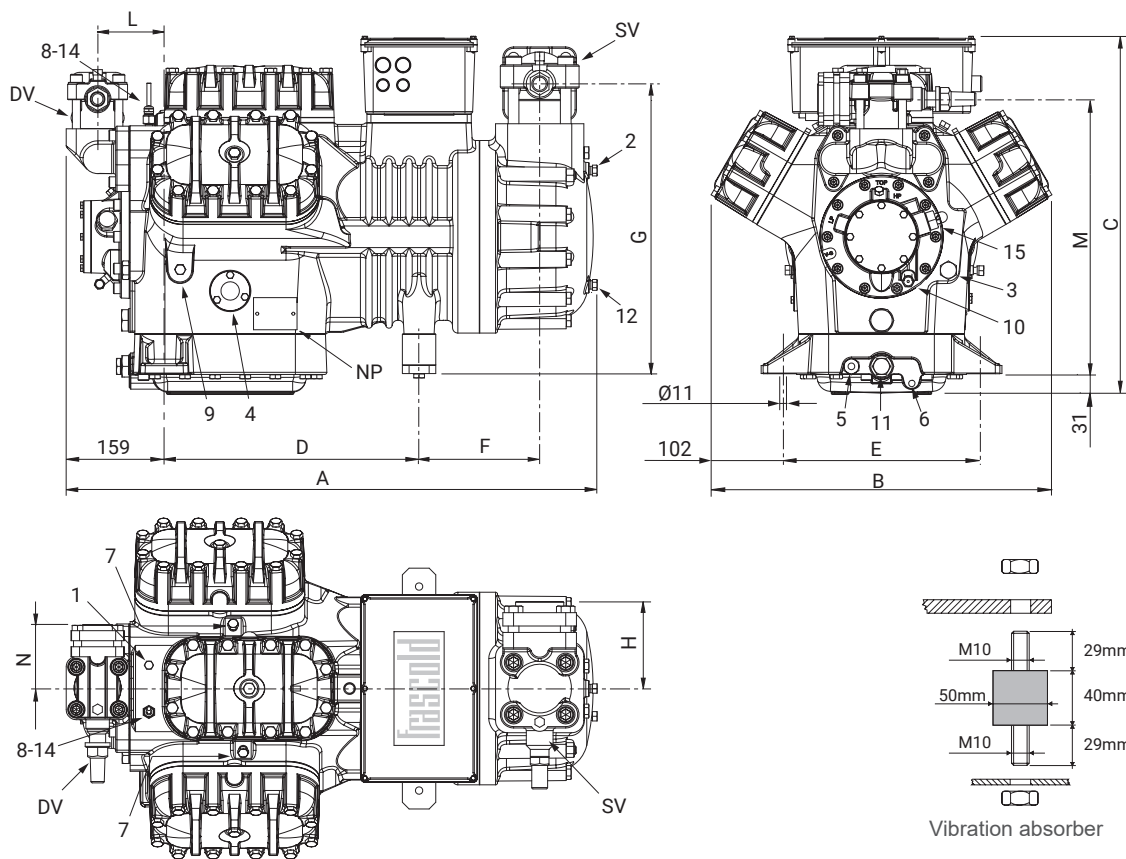

1	High pressure plug	1/8" NPT
2	Low pressure plug	1/4" NPT
3	Oil charge plug	3/8" GAS
4	Oil level sight glass	
5	Crankcase heater socket	
6	Oil drain plug	3/8" GAS
7	Liquid injection valve plug	1/8" NPT
8	Liquid injection sensor plug	1/8" NPT
9	Oil pressure switch connection (LP)	1/4" NPT
10	Oil pressure switch connection (HP)	1/4" SAE
11	Oil filter	3/8" GAS
12	Oil return plug	1/4" NPT
14	Max discharge temperature sensor	1/8" NPT
15	Electronic oil pressure switch connection	3/4" UNF
DV	Discharge valve	
SV	Suction valve	
NP	Nameplate	

Compressor	Compressor					Valves position						Valves				Net Weight
	Length	Width	Height	Base mounting		Suction			Discharge			Suction		Discharge		
	A	B	C	D	E	F	G	H	L	M	N	Ø	Ø	Ø	Ø	
Z40-140Y	794	509	536	381	305	180	433	130	100	411	95	2 ⁵ / ₈	67.0	1 ⁵ / ₈	42.0	240
Z50-140Y	794	509	536	381	305	180	433	130	100	411	95	2 ⁵ / ₈	67.0	1 ⁵ / ₈	42.0	244
Z40-154E	794	509	536	381	305	180	433	130	100	411	95	2 ⁵ / ₈	67.0	1 ⁵ / ₈	42.0	240
Z40-154Y	794	509	536	381	305	180	433	130	100	411	95	2 ⁵ / ₈	67.0	1 ⁵ / ₈	42.0	240
Z50-154Y	794	509	536	381	305	180	433	130	100	411	95	2 ⁵ / ₈	67.0	1 ⁵ / ₈	42.0	244

Dimensional Drawing Series W

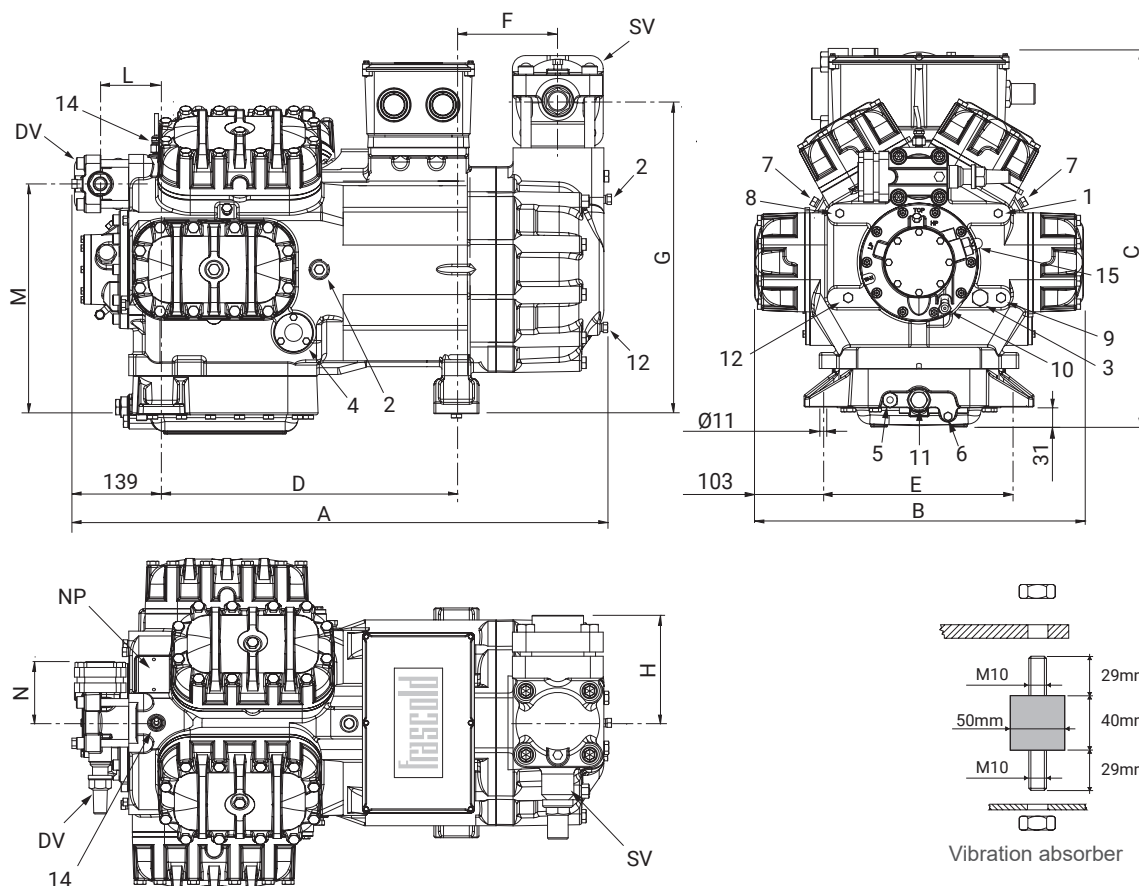

1	High pressure plug	1/8" NPT
2	Low pressure plug	1/4" NPT
3	Oil charge plug	3/8" GAS
4	Oil level sight glass	
5	Crankcase heater socket	
6	Oil drain plug	3/8" GAS
7	Liquid injection valve plug	1/8" NPT
8	Liquid injection sensor plug	1/8" NPT
9	Oil pressure switch connection (LP)	1/4" NPT
10	Oil pressure switch connection (HP)	1/4" SAE
11	Oil filter	3/8" GAS
12	Oil return plug	1/4" NPT
14	Max discharge temperature sensor	1/8" NPT
15	Electronic oil pressure switch connection	3/4" UNF
DV	Discharge valve	
SV	Suction valve	
NP	Nameplate	

Compressor	Compressor					Valves position						Valves				Net Weight
	Length	Width	Height	Base mounting		Suction			Discharge			Suction		Discharge		
	A	B	C	D	E	F	G	H	L	M	N	Ø	Ø	Ø	Ø	
W40-142Y	838	511	588	458	305	158	486	160	95	358	95	2 5/8	67.0	1 5/8	42.0	295
W40-168Y	838	511	588	458	305	158	486	160	95	358	95	2 5/8	67.0	1 5/8	42.0	299
W50-168Y	838	511	588	458	305	158	486	160	95	358	95	3 1/8	79.4	1 5/8	42.0	305
W50-187Y	838	511	588	458	305	158	486	160	95	358	95	3 1/8	79.4	1 5/8	42.0	311
W60-187Y	838	511	588	458	305	158	486	160	95	358	95	3 1/8	79.4	1 5/8	42.0	315
W60-206Y	838	511	588	458	305	158	486	160	95	358	95	3 1/8	79.4	2 1/8	54.0	320
W70-206Y	864	511	588	458	305	190	486	160	95	358	162	3 1/8	79.4	2 1/8	54.0	328
W70-228Y	864	519	588	458	305	190	486	160	95	358	162	3 1/8	79.4	2 1/8	54.0	328
W75-228Y	864	519	588	458	305	190	486	160	95	358	162	3 1/8	79.4	2 1/8	54.0	328
W75-240Y	864	519	588	458	305	190	486	160	95	358	162	3 1/8	79.4	2 1/8	54.0	328
W80-240Y	864	519	588	458	305	190	486	160	95	358	162	3 1/8	79.4	2 1/8	54.0	328



Frascold Headquarters

Frascold SpA Via B. Melzi 105 - 20027 Rescaldina (MI) Italy
Tel. +39 0331 742201 - Fax +39 0331 576102
mail: frascold@frascold.it - web: www.fracold.it

Subsidiaries

FRASCOLD CHINA

Frascold Refrigeration Co. Ltd
Room 608, 6th floor Jinqiao Life Hub
No.3611 Zhangyang Road
New Pudong District
Shanghai - CHINA
Ph. +86 021 58650192
Ph. +86 021 58650180
Fax +86 021 58650180
frascold.china@frascold.net
www.fracold.it

FRASCOLD INDIA PVT LTD

C-908, Titanium Square
Nr. Thaltej Cross Roads, S. G. Road
Thaltej, Ahmedabad - 380 054
Gujarat - INDIA
Ph. +91 79 2970 4046-49
Fax +91 79 2970 4049
sales@frascoldindia.com
www.fracoldindia.com

FRASCOLD USA

5901 23rd Drive West. Suite 101
Everett. WA 98203
Ph. (855) 547 5600 Office
info@frascoldusa.com
www.fracoldusa.com