

SEMI-HERMETIC SCREW COMPRESSORS

50 Hz // SP-100-5 EN

HS.53 // HS.64 // HS.74 // HS.85 // HS.95



WITH IQ MODULE

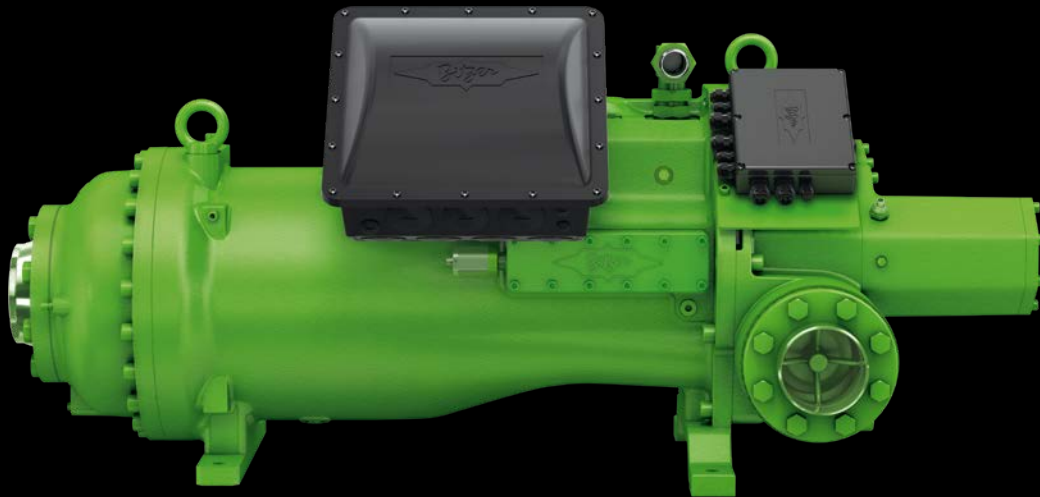

BIGGER MODELS



COMMERCIAL
REFRIGERATION



INDUSTRIAL
REFRIGERATION



MARINE



BITZER Innovation Targets

Products for refrigerants with low greenhouse warming potential (GWP)

- // For naturally appearing substances
- // For new refrigerants like R1234yf, R1234ze(E) and low-GWP blends

These refrigerants reduce the direct contribution of refrigeration systems to global warming.

Products with high efficiency at full and part load

- // Efficiency improvements of motor and mechanics
- // High system efficiency in part load operation
 - by optimised mechanical capacity regulation
 - by specially developed frequency inverters

This reduces the indirect contribution to global warming by saving energy.

Simple handling and serviceability with advanced electronic modules

- // Electronic components for
 - data logging
 - capacity regulation
 - actuation of accessories
- // Unified user software for simple configuration. Choose compressor or condensing unit and refrigerant. Ready.

This makes it simple to fully utilize the efficiency potential of our products and optimise operation.

Semi-hermetic screw compressors

HS. series

Displacements from 84 to 1015 m³/h at 50 Hz with parallel compounding up to 4060 m³/h

Contents	Page
The HSK and HSN screw compressors	3
The capacity range	3
Capacity control and V_i depending on construction size	4
Equipment and accessories	4
Other technical features	5
Refrigeration compressor oils	5
Oil management	6
Intelligent compressor protection and electronic oil monitoring	7
IQ MODUL CM-SW-01 for HS.95	8
VARIPACK – External BITZER Frequency Inverters	8
BEST SOFTWARE	9
New refrigerants with low warming potential	9
Application limits	10
Performance data	
BITZER SOFTWARE	12
ASERCOM certified performance data	12
Technical Data	13
Dimensional drawings	14

The semi-hermetic screw compressors of the HS. series are very versatile: they are suitable for low temperature refrigeration, for medium temperature application, for air conditioning and for heat pumps in commercial and industrial systems and in marine applications. They have been developed both for single compressor systems and for use in parallel compounding.

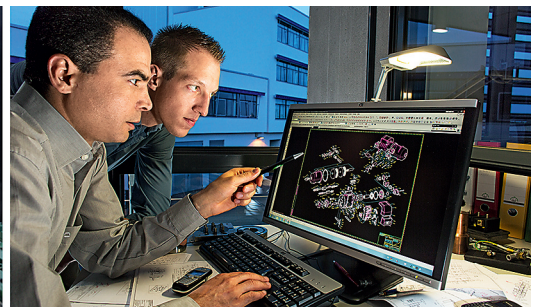
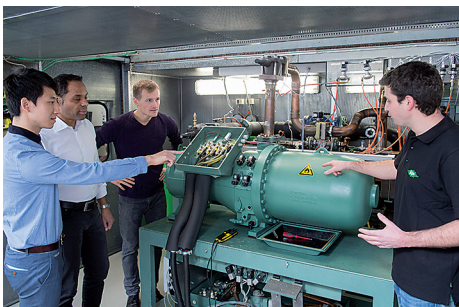

The HSK and HSN screw compressors

They set the worldwide standard for technological innovation, versatility and efficiency.

The capacity range

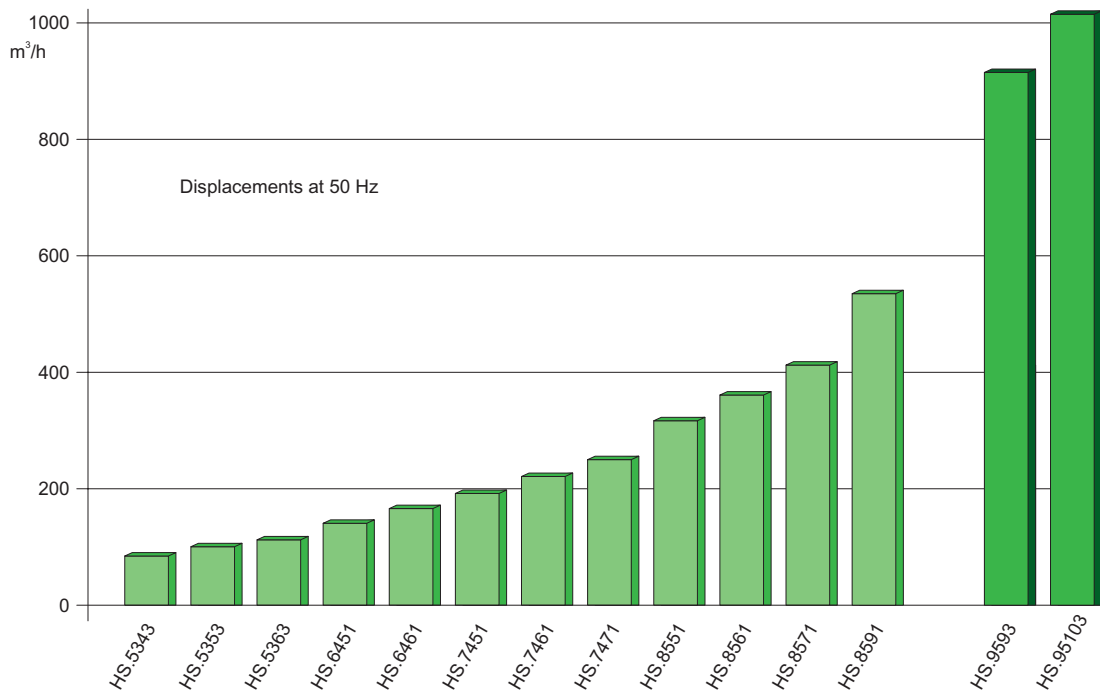

The special highlights

- // Energy efficient
 - high-efficiency profile
 - high motor efficiency
 - efficient capacity control
 - economiser operation (ECO)
- // Universal
 - R134a, R404A, R507A, R407A, R407C, R407F, R407H, R448A, R449A, R452A, R450A, R513A, R1234yf
 - with and without Economiser (ECO)
 - other refrigerants upon request
- // Robust design
 - generously dimensioned bearings
 - large volume motor
 - automatic start unloading
- // Low sound and low vibration
 - steady discharge characteristics
 - only rotating masses
- // Capacity control
 - particularly suitable for operation with frequency inverter (FI)
 - 20 .. 67 Hz with VARIPACK frequency inverters
 - 25 .. 60 Hz with other frequency inverters
 - mechanical capacity control
 - stepped for HS.53 to HS.74
 - stepless for HS.85 and HS.95

Versatile due to parallel compounding

- // High system performance
 - in parallel compounding up to 4060 m³/h at 50 Hz with four HS.95103
- // Optimum capacity adjustment and lowest power consumption at full and part load
 - combination of different compressor sizes possible
 - part load by simply switching off compressor
 - fine gradation by additional compressor capacity control or by operating a compressor with FI

Versatile in use

- // in commercial refrigeration systems
- // in industrial refrigeration systems
- // in marine applications



Capacity control and V_i depending on construction size

Capacity control

- // HS.53 to HS.74: Multi-stage capacity control
 - efficient capacity control by shifting of the suction port in two steps (75 and 50%)
 - hydraulically operated control pistons – at full load operation absolutely form-fit
 - both protection against liquid slugging and strong over-compression
 - simple control via flanged solenoid valves
- // HS.85: Dual capacity control
 - infinite or 3-stage slider control with V_i -compensation (for lower pressure ratios also 4-stage) Alternative operating mode by varying control sequence only – no need for compressor modification
 - easy control by flanged-on solenoid valves
- // HS.95: Stepless capacity control
 - efficient stepless capacity and V_i control due to an optimised slider concept
 - automatic V_i control
 - high efficiency in wide application limits
 - intelligent compressor monitoring module with extended protection concept and slider control

Automatic start unloading

Adjusted discharge ports

- // HSK models for air-conditioning and medium temperature applications
- // HSN models for low temperature application
- // HS.53 to HS.74: high efficiency over a wide application range due to the Duo-Port system: special port contour with additional radial outlet
- // HS.85: V_i adaption by capacity control slider
- // HS.95: automatic V_i control

Equipment and accessories

Complete equipment

- // Capacity control
- // Start unloading
- // Suction gas connection: flange with brazing and welding bush, for HS.53 to HS.74: suction gas shut-off valve
- // Discharge gas connection: flange with brazing and welding bush
- // Check valve in the discharge gas chamber
- // Integrated pressure relief valve according to EN12693 and UL60335-2-34
- // Electronic compressor protection device
- // Vibration dampers for HS.53, HS.64, HS.74
- // Kit for oil injection

Comprehensive range of accessories

- // Shut-off valves up to DN125
 - Discharge gas shut-off valve
 - Suction gas shut-off valve
- // ECO shut-off valve, depending on size with pulsation muffler
- // Connection adapter for liquid injection (LI), depending on size with integrated injection nozzle
- // Oil injection valve for every size
- // Vibration dampers for HS.85 and HS.95
- // Compressor protection devices with extended functions for HS.53 to HS.85
- // Heating element for the terminal box of HS.64 and HS.74
- // Oil separators of various capacity sizes with
 - oil heaters in pre-mounted heater sleeves
 - oil thermostat in pre-mounted heating sleeve
 - oil level switch
- // Air cooled oil coolers
- // Water cooled oil coolers
- // Thermosiphon oil cooling depending on system design upon request

Accessories for parallel compounding of up to 6 compressors

- // HS.53 to HS.85 up to 6 compressors
- // HS.95 up to 4 compressors
- // Selection and technical data see BITZER SOFTWARE.

Other technical features

Optimised emergency running characteristics

- // Rotors with roller bearings on both sides
 - radial and axial
- // Generously sized oil supply reservoir
- // Check valve in the discharge chamber as protection against reverse running at standstill
- // Integrated pressure relief valve

Economiser operation (ECO)

- // Increased capacity and efficiency at medium and high pressure ratios
- // Close to ideal compression
- // Significant increase in capacity density and system efficiency

Refrigeration compressor oils

BSE170

- // Viscosity: 170 cSt at 40°C
- // Maximum allowable oil injection temperature: 100°C
- // For all permitted refrigerants except R22
- // Within the documented application limits

B150SH and B100

- // Viscosity: B150SH 150 cSt, B100 100 cSt each at 40°C
- // maximum allowable oil injection temperature: B150SH 100°C, B100 80°C
- // for R22
- // B150SH within the documented application limits from $t_o \geq -40^\circ\text{C}$,
- // B100 for low temperature range up to $t_c \leq 45^\circ\text{C}$ and $t_o \leq -5^\circ\text{C}$

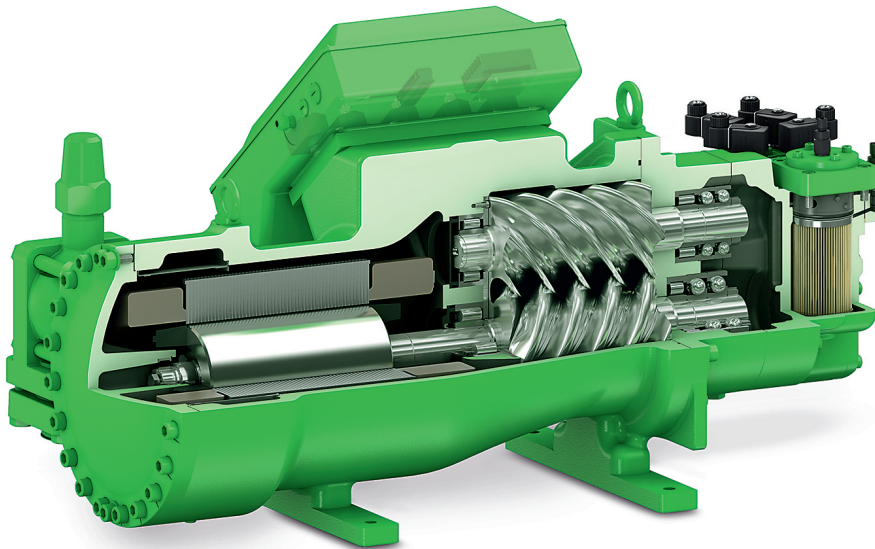

Model designation

Example

HSK 95103 - 320 - 40D

Semi-hermetic screw compressor

HSK 95103 - 320 - 40D

Application range

K = Air conditioning and medium temperature application

N = Low temperature application

HSK 95103 - 320 - 40D

Housing size

HSK 95103 - 320 - 40D

Displacement

HSK 95103 - 320 - 40D

Compressor execution

HSK 95103 - 320 - 40D

Motor size and design

HSK 95103 - 320 - 40D

Motor code

Oil management

- // complete accessories for oil injection
- // simple parallel compounding
- // no oil pump required

HS.53, HS.64 and HS.74

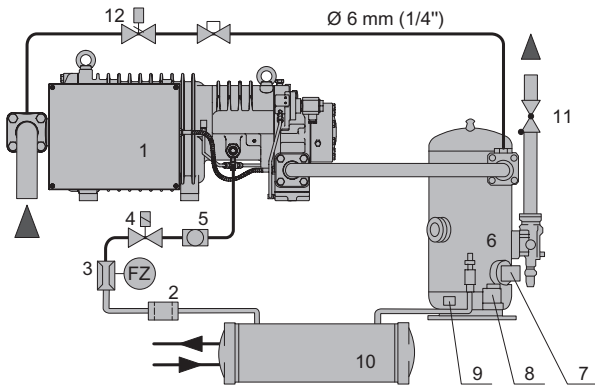

- | | |
|--------------------|--|
| 1 Compressor | 2 Oil filter |
| 3 Oil flow switch | 4 Solenoid oil valve |
| 5 Sight glass | 6 Oil separator |
| 7 Oil level switch | 8 Oil thermostat |
| 9 Oil heater | 10 Oil cooler, only if required |
| 11 Check valve | 12 Solenoid valve as standstill bypass, only when required |

Accessories for the oil injection line, included in the scope of delivery:

- // Oil filter
- // Oil flow switch
- // Electronic oil monitoring
- // Solenoid oil valve
- // Oil sight glass

HS.85

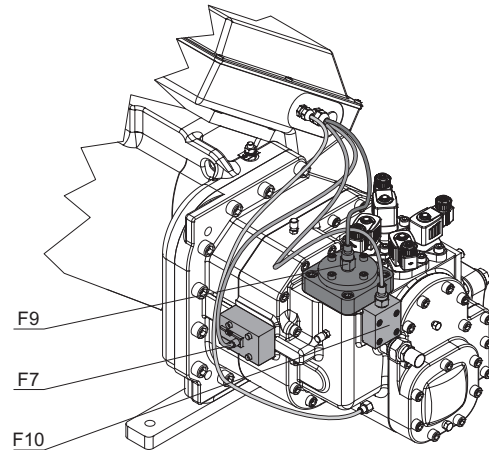

- F7 Oil supply monitoring
- F9 Oil stop valve
- F10 Oil filter monitoring

Oil management system integrated in the compressor, only a few components are required in the oil line, which are included in the scope of delivery:

- // Shut-off valve
- // Oil sight glass

HS.95

Oil supply monitoring integrated in the compressor, oil line components included in the scope of delivery:

- // Solenoid oil valve
- // Oil filter

Intelligent compressor protection and electronic oil monitoring

The compressor protection devices of the semi-hermetic screw compressors monitor and protect beyond the requirements of EU standards. Contained in scope of delivery:

HS.53, HS.64, HS.74

SE-E1 + SE-B2 with accessories

HS.85

SE-E1 + 2 SE-B2 with accessories

HS.95

IQ MODULE CM-SW-01

Compressor protection devices

Intelligenter Verdichterschutz	SE-E1	SE-E3	SE-i1	CM-SW-01
suitable for	HS.53 HS.64 HS.74 HS.85	HS.53 HS.64 HS.74 HS.85	HS.53 HS.64 HS.74 HS.85	HS.95
Motor voltage	200 .. 600V	600 .. 690V	200 .. 690V	83 .. 690V
Motor frequency	50/60 Hz ~	50/60 Hz ~	FI operation/ soft starter	FI operation
Permitted ambient temperature	-30 .. +60°C	-30 .. +60°C	-30 .. +60°C	-30 .. +70°C
Thermal motor monitoring	✓	✓	✓	✓
Monitoring of the discharge gas temperature	✓	✓	✓	✓
Rotation direction monitoring	✓	✓	✓	✓
Phase failure monitoring	✓	✓	✓	✓
Restart delay	✓	✓	✓	✓
Suitable for FI operation			✓	✓
Monitoring of the oil supply	additional device required	additional device required	✓	✓
Monitoring of the cycling rate			✓	✓
Monitoring of application limits			✓	✓
Low pressure cut out				✓
High pressure switch			✓	✓
Status LEDs			✓	✓
Data log			✓	✓
Early warning system			✓	✓
Communication (BEST/Modbus)			✓	✓
CE and UL approval	✓		✓	✓

Oil monitoring

HS.53, HS.64, HS.74

// Oil flow switch is accessory

// Electrical accessories in the switch cabinet for 2 alternative monitoring concepts

- SE-B2 and electrolytic capacitor with time relay
- Option for HS.53: OFC (Oil Flow Control)

HS.85

// Integrated oil management system

- automatic oil stop valve
- integrated oil filter
- monitoring of oil flow and oil filter for contamination and pressure drop

// Electrical accessories in the switch cabinet

- SE-B2 for the integrated oil flow switch
- monitoring of the oil supply and the oil stop valve: SE-B2 and electrolytic capacitor with 2 time relays

HS.95

// Monitoring of the oil supply integrated into the IQ MODULE

For details on the protection devices see Technical Information ST-120, for details on the function and operation of the CM-SW-01 see ST-150.



IQ MODULE CM-SW-01 for HS.95

The new generation of extended BITZER compressor modules operates, monitors and protects screw compressors reliably and communicates with the superior system controller. Sensors and actuators are pre-wired and preconfigured ex works by BITZER.

The new, extended protection concept

- // Intelligent activation to improve system efficiency
 - start unloading
 - V_1 control
 - capacity control
- // Monitored compressor parameters
 - motor and discharge gas temperature
 - oil monitoring with oil pressure transmitter and oil level switch in the compressor
 - rotation direction
 - high and low pressure
 - high pressure switch
 - monitoring of application limits
- // Diagnosis
 - an early warning system reports critical operating conditions
 - data log of all digital and analog inputs and outputs
 - history of alarm and warning messages
 - operating time and load statistics
- // Communication
 - via Modbus (standardised interface)
 - via Bluetooth
 - configuration and operational monitoring via the BEST SOFTWARE
 - status LEDs for fast initial diagnosis



IQ INTELLIGENT PRODUCTS

VARIPACK – External BITZER Frequency Inverters

For easy and safe capacity control, BITZER VARIPACK series offers a new generation of intelligent frequency inverters that can be used with all BITZER reciprocating compressors.

The product, a new generation of intelligent frequency inverters with which the HS.53 to HS.85 semi-hermetic screw compressors can be operated.

The new VARIPACK frequency inverter series was specially developed for refrigeration and the operation of BITZER refrigeration compressors. The focus of development was the ease of operation, reliability and high performance of the frequency inverters.

Selection and assignment

The VARIPACK frequency inverters are fully integrated into the BITZER SOFTWARE and can be found under the "Accessories" button.

The visualisation of the resulting application limit allows you to create an efficient, reliable in operation and cost-effective system design, even without extensive special knowledge of frequency inverters and manual calculation steps.

Operation

Communication with the VARIPACK frequency inverters for configuration, monitoring and reading out of fault messages can be done out by:

- // The BEST SOFTWARE
- // The control panel.



 FREQUENCY INVERTER

Via PC, a lot of BITZER IQ products may be configured with the BEST SOFTWARE. With its intuitive user interface displays a complete operating status overview including data log for easy maintenance and service. This is completely in line with our innovation targets.

Easy configuration

- // Easy device parameterisation
- // Storage and installation of device and compressor setups
- // Safe and easy firmware update

Reliable online diagnosis

- // Display of all connected sensors, e. g. pressure transmitters, temperature sensors, oil level switches, digital and analog inputs and outputs
- // Current operating point in the application limit
- // Current capacity control status

Comfortable analysis

- // Data log download and visualisation of all operating parameters
- // Alarm list with integrated help function for easy maintenance and service

Communication

- // Via BEST interface converter and Bluetooth

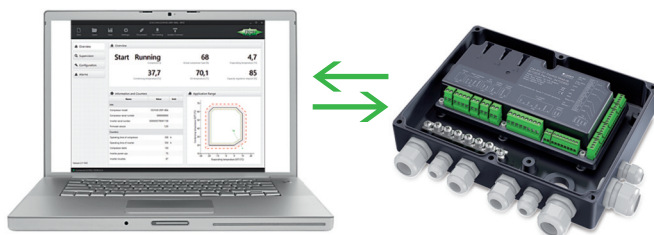

New refrigerants with low warming potential

The semi-hermetic screw compressors can be used with new low global warming potential (GWP) refrigerants. These refrigerants are important tools to reach the emission reductions of the EU Regulation 517/2014 and similar scenarios clearly decided worldwide. This application is part of our innovation targets.

The unsaturated fluorinated hydrocarbon (HFO) R1234yf, a variant of tetrafluoropropene, plays a central role in this. It can be used as pure substance or as a component of blends – see also the application limits.

The pure substance R1234yf is classified as flammable in A2L according to ISO817. For flammable refrigerants, a risk assessment for the system has to be made reflecting the flammability and it must be constructed in accordance with national or local regulations. If the risk assessment classifies the installation area as an explosion protection zone, the HS. compressors are not applicable. Consultation with BITZER is absolutely necessary.

Blends such as R450A and R513A are close to R134a in characteristics and performance and are also not flammable. They can be used with the same safety measures at the system as with R134a. Further information on these refrigerants can be found in Refrigerant Report A-501.

Performance data for the entire application range are available in the BITZER SOFTWARE.

Application limits

HS.53 .. HS.85

R448A ■ R449A ■ R407A ■ R407F CR100%

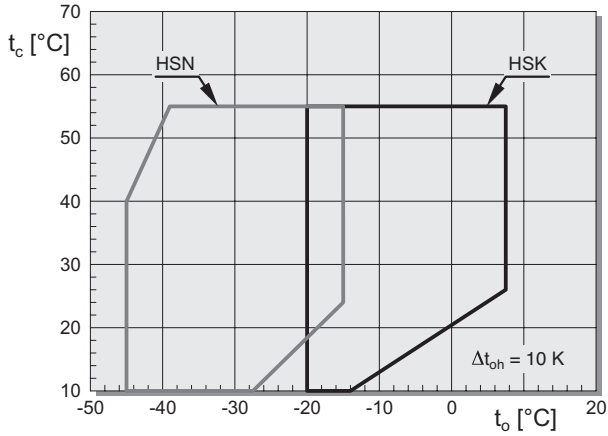

R448A ■ R449A ■ R407A ■ R407F CR75% ■ CR50%

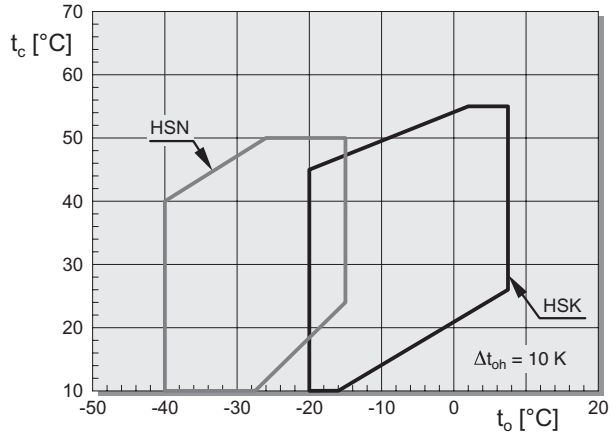

R404A ■ R507A CR100%

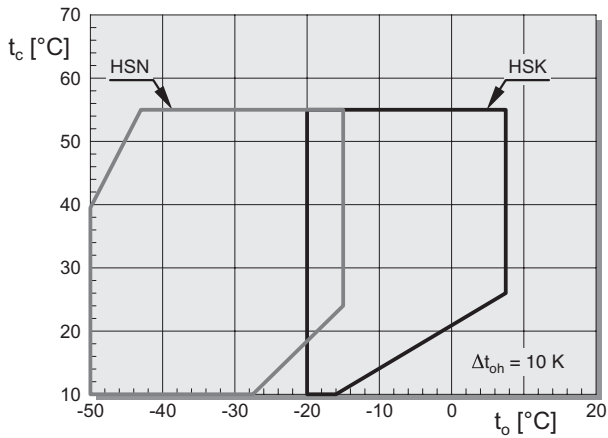

R404A ■ R507A CR75% ■ CR50%

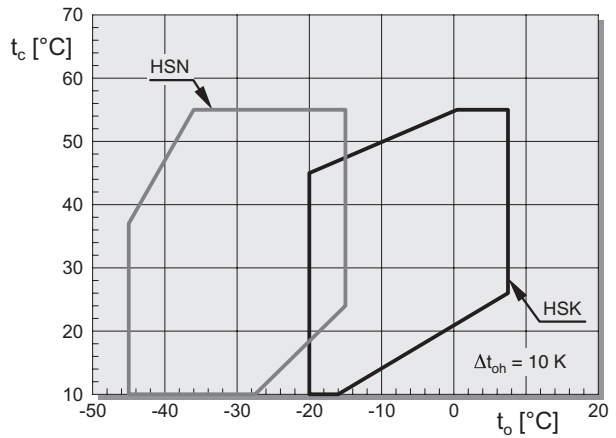

R134a ■ R513A ■ R450A ■ R1234yf

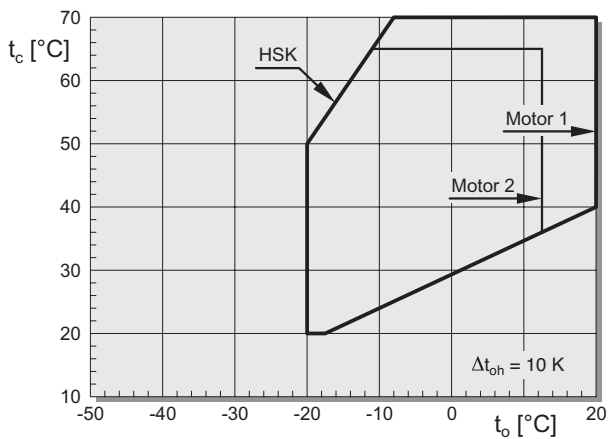

R407C

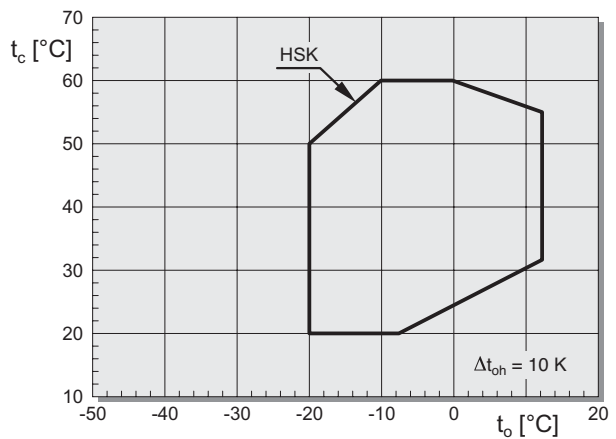

Application limits

HS.53 .. HS.85

R22 CR100%

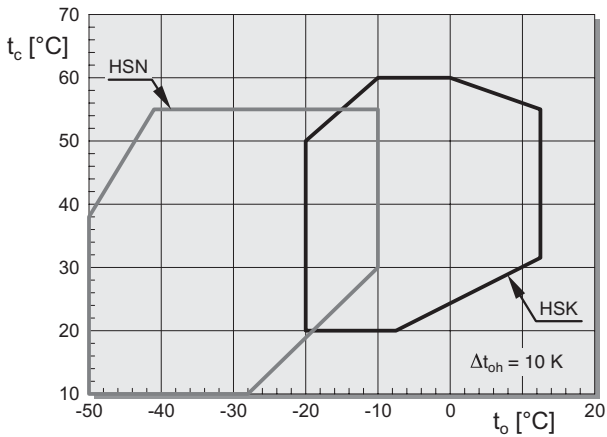

R22 CR75% ■ CR50%

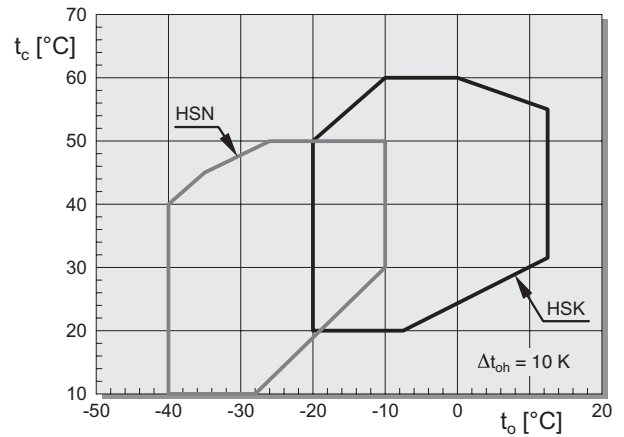

HS.95

R448A ■ R449A ■ R407A ■ R407F

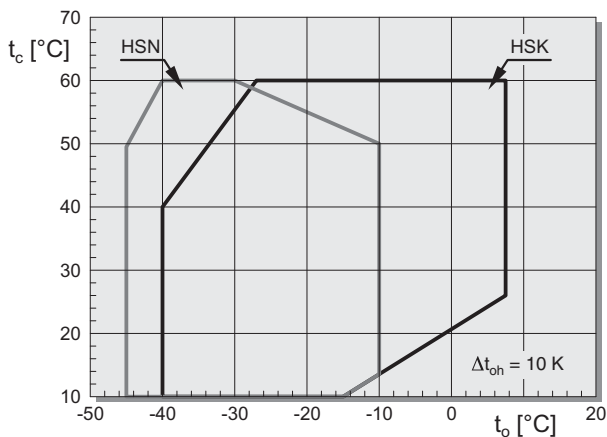

R404A ■ R507A

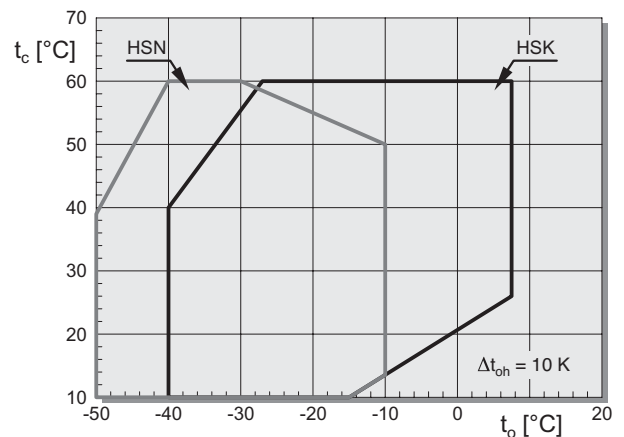

R134a ■ R513A ■ R450A ■ R1234yf

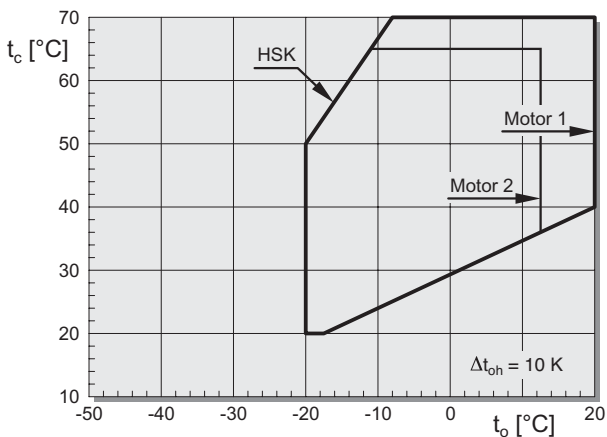

Legend

- t_o Evaporation temperature (°C)
- t_c Condensing temperature (°C)
- Δt_{oh} Suction gas superheat (K)

Oil cooling

For ranges in which oil cooling becomes necessary see BITZER SOFTWARE. Here, the required oil cooler capacity can be determined.

ECO operation

Maximum condensing temperature may be limited. For ECO application limits, see BITZER SOFTWARE.

With HS.53 to HS.74 in ECO operation, the capacity control is limited to one regulation step (CR 75%). Exceptions are possible depending on the operating conditions. This requires individual coordination with BITZER. Use both regulation steps for start unloading only.

Application limits for HS.95:

Tentative data



Performance data



The BITZER SOFTWARE is available in many languages as a download for Windows as well as a web-based version. It is compatible with any browser and always up to date. The program is also suitable for tablets and smartphones.

The BITZER SOFTWARE covers:

- // Performance data for all common refrigerants under freely selectable operating conditions
- // All relevant technical data
- // Calculation results and individually defined performance tables for compressors
- // Seasonal calculation
- // Compound connection
- // Available accessories and their selection
- // All relevant technical documents
- // Further BITZER products

bitzer-software.com

ASERCOM certified performance data

The Association of European Refrigeration Component Manufacturers (ASERCOM) has implemented a procedure of certifying compressor performance data.

The high standard of this certification is guaranteed by

- // plausibility checks of data carried out by experts
- // regular random tests at independent institutes

These high efforts result in the fact that only a limited number of compressors can be submitted. Due to this not all BITZER compressors are certified yet.

Performance data of compressors which meet the strict requirements may carry the label "ASERCOM certified product". All certified compressors and further information are listed on the ASERCOM web site (www.ASERCOM.org).



In the BITZER SOFTWARE the appropriate compressors are marked with this label.

Performance data

Performance data based on European standard EN12900 and 50 Hz operation. Evaporation and condensing temperatures correspond to "dew point" conditions (saturated vapor).

Standard conditions

With standard conditions, no liquid subcooling is considered according to EN12900. Therefore the rated cooling capacity and efficiency (COP) show lower values in comparison to data based on 5 or 8.3 K of subcooling.

Economiser operation (ECO)

Data for economiser operation inherently include liquid subcooling. The liquid temperature is defined as 5 K above saturated temperature according to EN12900 at economiser inlet ($t_{cu} = t_{ms} + 5 \text{ K}$).

The screenshot shows the BITZER Software interface with the following details:

- Series:** Semi-hermetic Screw Compressors HS
- Refrigerant:** R404A
- Reference temperature:** Dew point temp.
- Compressor selection:** Cooling capacity (200 kW)
- Operating point:** Evaporating SST (-10 °C), Condensing SDT (45 °C)
- Operating conditions:** with Economiser, Liq. subc. (in condenser) (0 K), Suct. gas superheat (10 K), Useful superheat (100 %), Additional cooling (Automatic), Max. discharge gas temp. (Auto)
- Power supply:** 50Hz, Standard (400V)

The technical data table for compressor HSK8561-125 is as follows:

Compressor	HSK8561-125	HSK8571-140
Capacity steps	100%	100%
Cooling capacity	185.4 kW	214 kW
Cooling capacity *	185.4 kW	214 kW
Evaporator capacity	185.4 kW	214 kW
Power input	96.9 kW	109.0 kW
Current (400V)	161.5 A	180.8 A
Voltage range	380-415V	380-415V
Condenser Capacity	278 kW	318 kW
COP:IEER	1.91	1.96
COP:IEER *	1.91	1.96
Mass flow LP	6573 kg/h	7584 kg/h
Mass flow HP	6573 kg/h	7584 kg/h
Operating mode	Standard	Standard
Liquid temp.	44.7 °C	44.7 °C
Oil volume flow	2.46 m ³ /h	2.46 m ³ /h
Cooling method	--	--
Discharge gas temp. w/o cooling	74.1 °C	73.0 °C

Technical Data

Model	Motor version ①	Displacement 50/60 Hz ② m ³ /h	Cooling capacity Q ₀			Capacity steps nominal ③ %	Weight ⑤ kg	Motor connection ⑥	Max. operating current ⑦ A	Max. power consumption ⑦ kW
			R134a t ₀ / t _c 5°C/50°C kW	R448A R449A t ₀ / t _c -10°C/45°C kW	R448A R449A t ₀ / t _c -35°C/40°C with ECO kW					
HSK5343-30	1	84/101	46.4	40.8	–	100/90/70	170	400V±10%/Δ/Δ-3-50 Hz 460V±10% 460V±10%/Δ/Δ-3-60 Hz Part winding	52	33
HSN5343-20	1		–	–	21.7	100/90/55	166		48	29
HSK5353-35	1	100/121	56.7	49.3	–	100/85/60	178		58	37
HSN5353-25	1		–	–	25.6	100/80/50	169		52	33
HSK5363-40	1	118/142	67.2	58.7	–	100/80/55	183		66	42
HSN5363-30	1		–	–	29.9	100/75/45	174		58	37
HSK6451-40	2	140/168	81.1	–	–	100/85/60	234		65	35
HSK6451-50	1		81.1	71.5	–	100/85/60	238		79	50
HSN6451-40	1		–	–	36.0	100/75/50	234		65	42
HSK6461-40	2	165/198	96.8	–	–	100/80/55	238		65	42
HSK6461-60	1		96.8	86.0	–	100/80/55	246		98	65
HSN6461-50	1		–	–	42.2	100/75/45	238		79	52
HSK7451-50	2	192/232	117.3	–	–	100/75/45	297		79	51
HSK7451-70	1		117.3	104.0	–	100/75/45	305		124	75
HSN7451-60	1		–	–	50.6	100/80/65	297		98	65
HSK7461-60	2	220/266	134.9	–	–	100/70/40	310		98	56
HSK7461-80	1		134.9	119.2	–	100/70/40	314		144	85
HSN7461-70	1		–	–	58.3	100/75/60	310		124	75
HSK7471-70	2	250/302	146.6	–	–	100/60/40	326		124	85
HSK7471-90	1		146.6	130.5	–	100/60/40	336		162	92
HSN7471-75	1		–	–	62.5	100/75/55	326	144	85	
HSK8551-80	2	315/380	179.6	–	–	100 ⇔ 50 or 100/75/50 ④	550	144	88	
HSK8551-110	1		179.6	161.5	–		565	180	110	
HSK8561-90	2	359/433	205	–	–		560	155	96	
HSK8561-125	1		205	184.6	–		575	216	132	
HSN8561-110	1		–	–	86.1		565	196	126	
HSK8571-110	2	410/495	237	–	–		565	182	110	
HSK8571-140	1		237	213	–		580	246	150	
HSN8571-125	1		–	–	103.9		575	216	132	
HSK8581-125	2	470/567	260	–	–		585	215	118	
HSK8581-160	1		260	248	–		605	277	162	
HSK8591-140	2	535/646	300	–	–	590	246	135		
HSK8591-180	1		300	277	–	620	330	181		
HSN8591-160	1		–	–	129.0	610	274	157		
HSK9593-240	2	910/1090	520	–	–	100 ⇔ 25	1070	⑧	⑧	
HSK9593-280	1		520	445	206		1100	⑧	⑧	
HSK95103-280	2	1015/1220	590	–	–		1100	⑧	⑧	
HSK95103-320	1		590	510	–		1120	664	421	
HSN95103-280	1		–	–	236		1100	⑧	⑧	

① Motor 2: Compressor specially optimised for R134a for air conditioning and medium temperature application up to max. 65°C condensing temperature

② 50 Hz: at 2900 min⁻¹, 60 Hz at 3500 min⁻¹

③ Effective capacity steps depend on operating conditions.
K models -10/45°C (without ECO)
N models -35/40°C (without ECO)

④ 25%: integrated alternating current voltage or HSK with low pressure ratio

⑤ Weight according to standard delivery condition:
HS.53 to HS.74 with suction gas shut-off valve and discharge gas flange, HS.85 and HS.95 with suction gas and discharge gas flange, each with brazed bush. Additional weight of the optional shut-off valves:
Ø42 mm (1 5/8"): 3 kg Ø76 mm (3 1/8"): 10 kg
Ø54 mm (2 1/8"): 5 kg DN100: 20 kg
Ø64 mm (2 5/8"): 10 kg DN125: 50 kg

⑥ Other voltages and currents upon request.

⑦ Data valid for 50 Hz operation. For the selection of contactors, cables and fuses the max. operating current/max. power consumption must be considered.
Contactors: Operational category AC3

⑧ Data upon request

Dimensional drawings

HS.53..

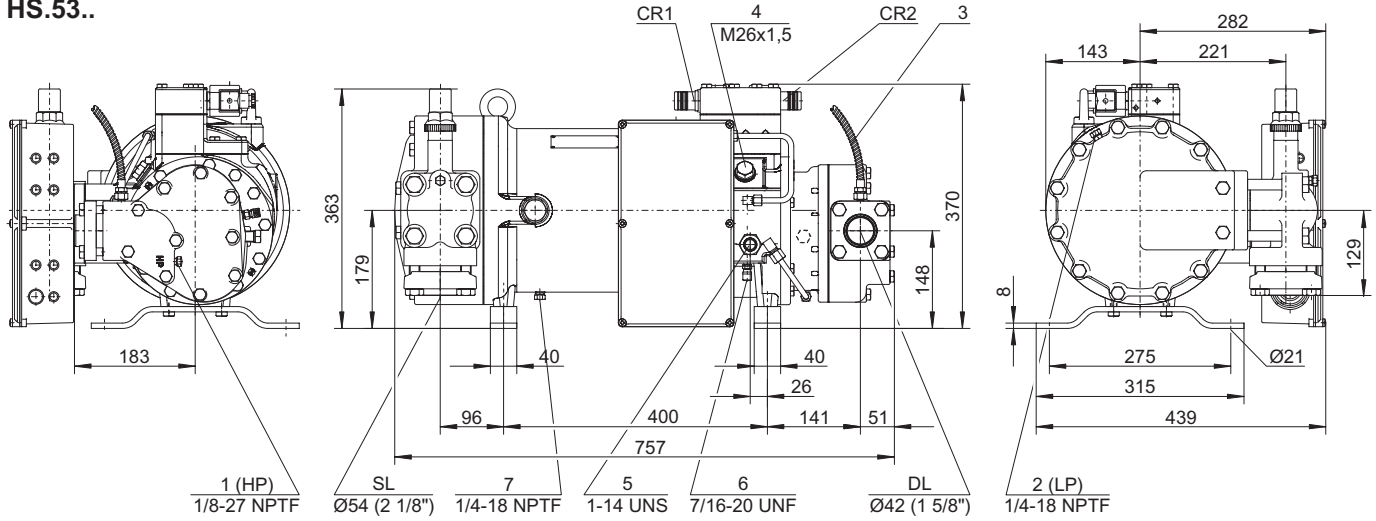

HS.64..

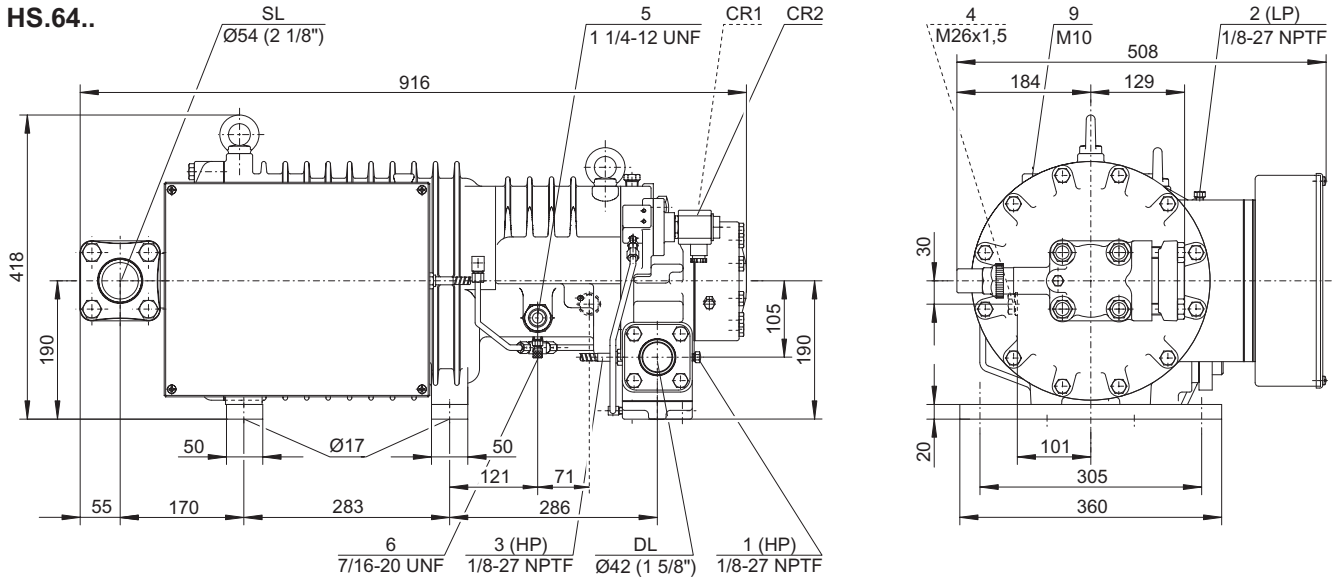

HS.74..

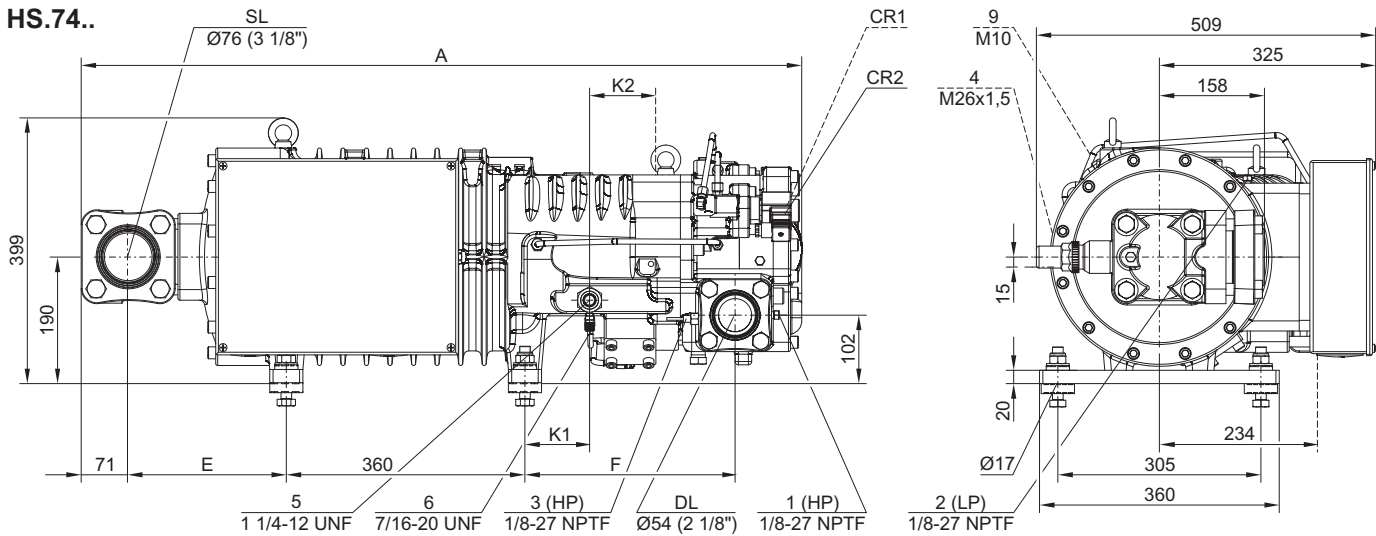

Model	A	E	F	K1	K2
HS.7451, HS.7461	1021	186	295	76	109
HSK7471-70, HSN7471-75	1034	186	318	98	97
HSK7471-90	1087	238	318	98	97

Dimensional drawings

HS.8551 .. HS.8571

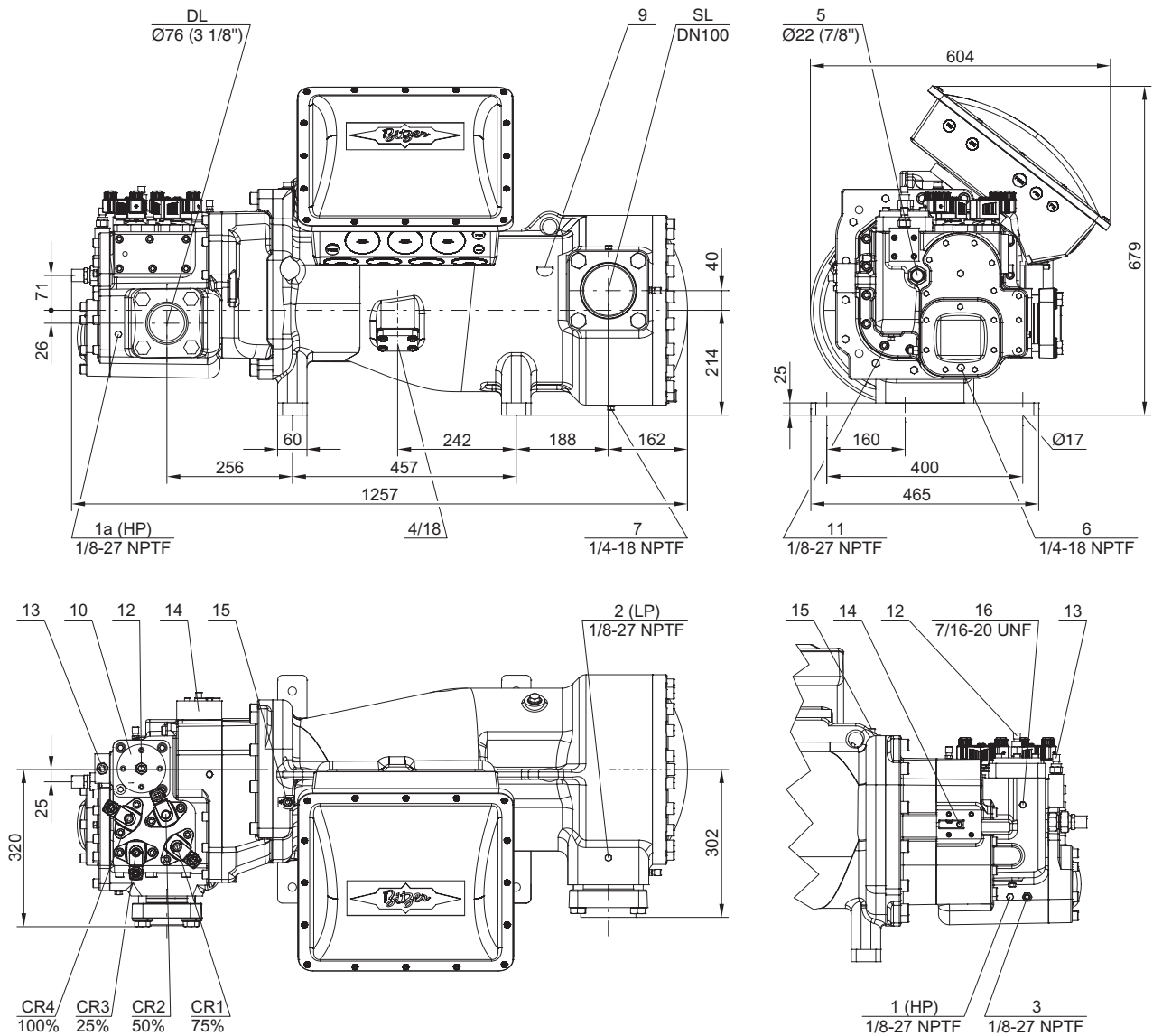

Dimensional drawings

HS.8581, HS.8591

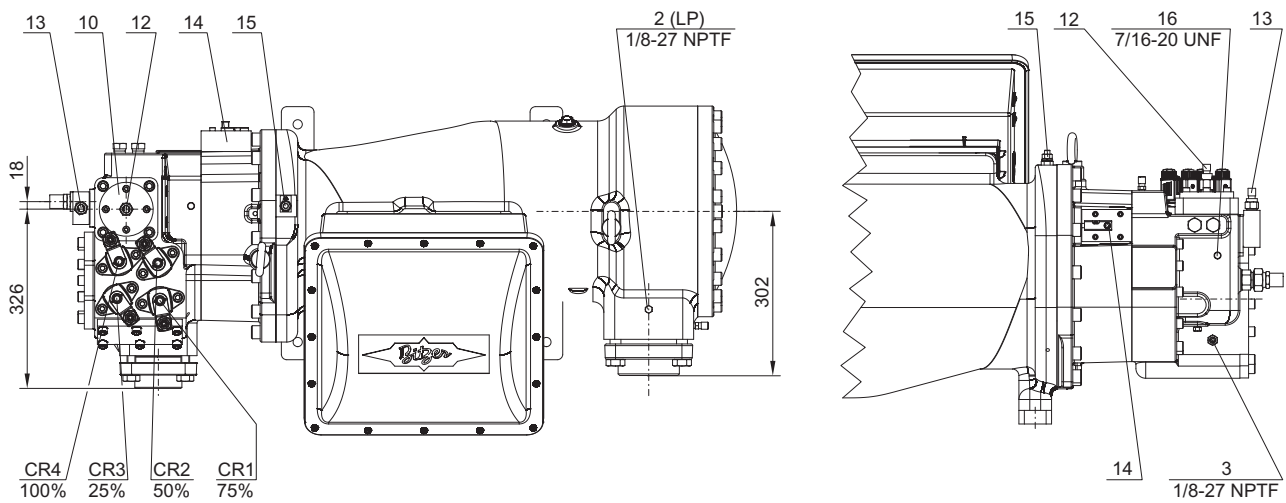
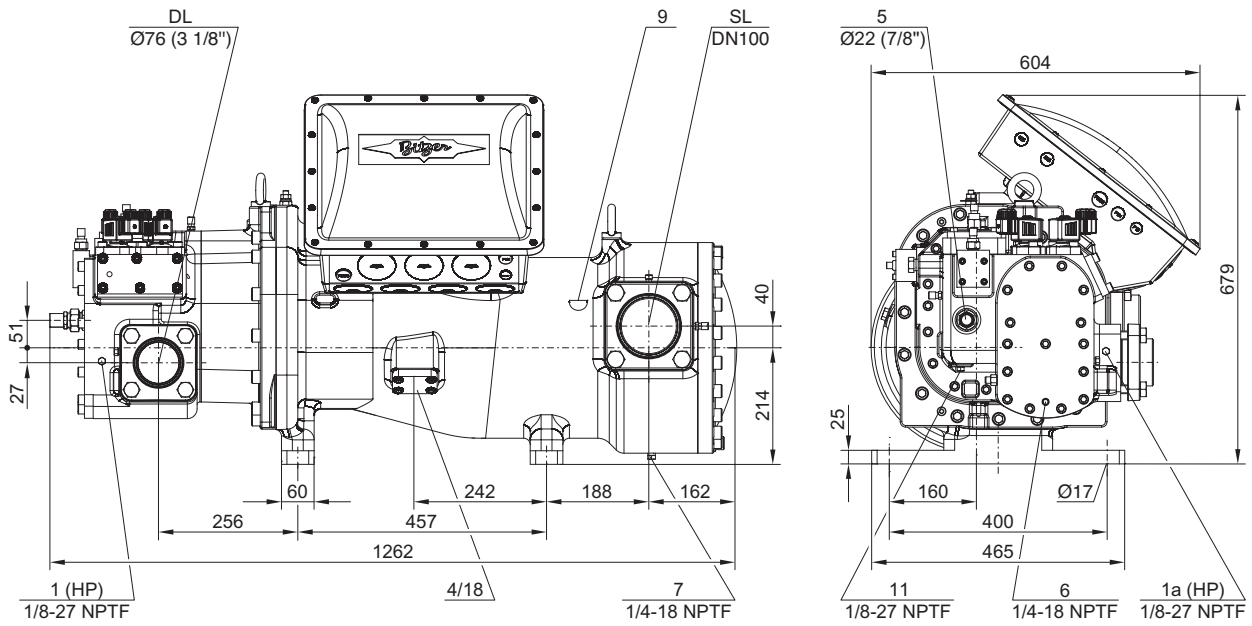

Dimensional drawings

HS.95..

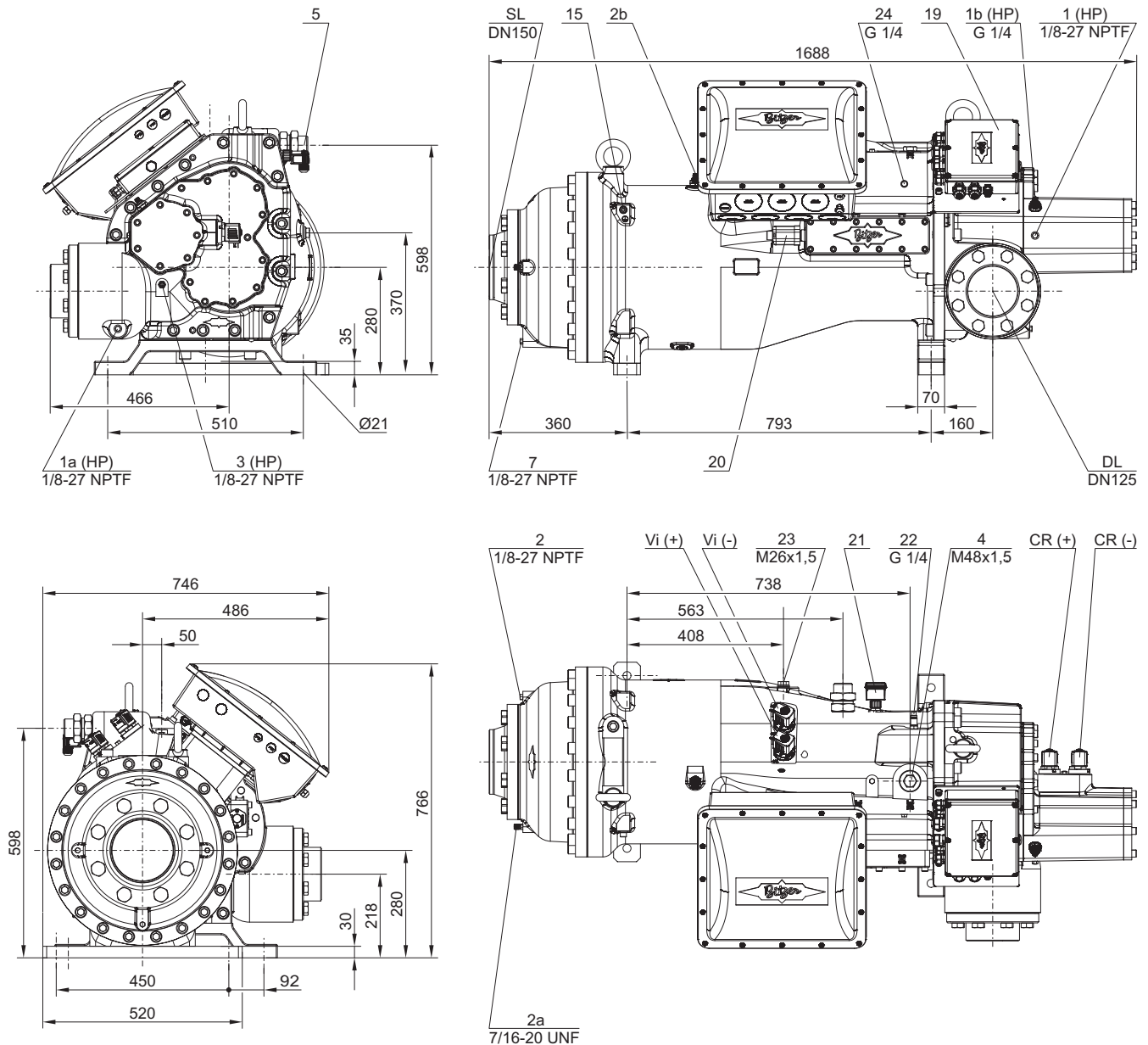

Connection positions

- | | |
|---|--|
| 1 High pressure connection (HP) | 11 Oil drain (oil filter) |
| 1a Additional high pressure connection (HP)
(not suitable for pressure measurement!) | 12 Monitoring of oil stop valve |
| 1b Connection for high pressure transmitter (HP) | 13 Oil filter monitoring |
| 2 Low pressure connection (LP) | 14 Oil flow switch |
| 2a Additional low pressure connection (LP) | 15 Earth screw for housing |
| 2b Connection for low pressure transmitter (LP) | 16 Pressure blow-off (oil filter chamber) |
| 3 Connection for discharge gas temperature sensor (HP) | 18 Liquid injection (LI) |
| 4 Connection for economiser (ECO) | 19 Compressor module |
| HS.85: ECO valve with connection line (option) | 20 Slider position indicator |
| HS.95: ECO valve (option) | 21 Oil level switch |
| 5 Connection/valve for oil injection | 22 Oil pressure transmitter |
| 6 Oil pressure connection | 23 Connection for oil and gas return (for systems with
flooded evaporator adaptor optional) |
| HS.85: Oil drain (compressor housing) | 24 Access to oil circulation restrictor |
| 7 Oil drain (motor housing) | |
| 9 Threaded bore for pipe fixture (ECO and LI lines) | SL Suction gas line |
| 10 Maintenance connection for oil filter | DL Discharge gas line |



BITZER Kühlmaschinenbau GmbH
Eschenbrünnelestraße 15 // 71065 Sindelfingen // Germany
Tel +49 [0]70 31 932-0 // Fax +49 [0]70 31 932-147
bitzer@bitzer.de // www.bitzer.de

Subject to change // 80143301 // 09.2018