



HANDBOOK
OIL CONTROL SYSTEMS

Ed. 2017



CHAPTER 1 ■ OIL SEPARATORS

FOR REFRIGERATION PLANTS THAT USE HCFC, HFC OR HFO REFRIGERANTS



APPLICATIONS

The oil separators illustrated in this chapter are designed for installation on commercial refrigeration systems and on civil and industrial air conditioning plants that use the following refrigerant fluids:

- HCFC (R22)
- HFC (R134a, R404A, R407C, R410A, or R507)

belonging to Group 2, as defined in Article 13, Chapter 1, Point (b) of Directive 2014/68/EU, with reference to EC Regulation No. 1272/2008.

For specific applications with refrigerant fluids not listed above, please contact Castel Technical Department.

The advantages of the oil separator on the discharge line of a compressor in a refrigeration system are confirmed by many years of experience. The oil separator intercepts the oil mixed with compressed gas and returns it to the oil reservoir or to the compressor crankcase, ensuring efficient lubrication of its moving parts. Furthermore, by eliminating or reducing the oil film on the condenser and evaporator heat exchange surfaces, it maintains a high heat exchange coefficient in this equipment. When a very high temperature at the end of the compression stage leads to the formation of oil vapours, a separator with a capacity exceeding the values shown in the table should be used. Moreover, the oil separator, damping the pulsing from the valves, reduces the system noise in open or semi-hermetic compressors.

Finally, the use of an oil separator leads to:

- Longer compressor life;
- Better performance of the whole system with consequent energy savings;
- Quieter operation by reducing pulsing.

Tables 1 and 3 show the data relating to the operating conditions of oil separators.

CONSTRUCTION

Castel manufactures two types of oil separators:

- Separators in series 5520 can be inspected for maintenance and can be removed from the system. They are equipped with threaded connections, which can mate to the connections type 5590 (to be ordered separately)
- Separators in series 5540 are hermetically closed and cannot be disassembled from the system, except by cutting the piping.

The separator body is composed by a steel pipe of adequate thickness. The flanges and cover are also made of steel. Both the threaded connections of separators in series 5520 or the solder connections of separators in series 5540 are machined from steel bar EN 10277-3 11S Mn Pb 37 + C. The internal device is simple to ensure a trouble-free long-term operation.

Appropriate metal screens, placed on the inlet and outlet, along with the rapid reduction in gas speed create ideal conditions for separating the oil from the refrigerant.

A float mechanism, located on the bottom of the vessel, returns the oil to the compressor.

The bottom of the separator also includes a chamber for collecting any iron debris. A permanent magnet holds these impurities to avoid they clog or damage the operation of the float-controlled needle.

HOW TO CHOOSE AN OIL SEPARATOR

An oil separator must be sized based on the characteristics of the compressor installed, once the following have been defined:

- Inlet connection corresponding to the discharge diameter of the compressor
- Refrigerant fluid power for the established operating conditions (discharge saturation temperature, suction saturation temperature, any liquid subcooling, overheating of suction vapour).

This is necessary to define, for an end compression temperature assigned, the gas speed in reference to the gross section of the oil separator. It is advisable that the above-mentioned speed does not exceed 0.4 m/s, to avoid excessive turbulence.

Generally, once the refrigerating potential of the compressor has been assigned, based on the type of refrigerant and operating conditions, the volumetric flow rate, Q , of the compressed gas, is given by:

$$Q = \frac{P}{\Delta H} \times v_g \quad [\text{m}^3/\text{s}]$$

where:

- P = refrigerant potential [kW]
- ΔH = enthalpy of superheated vapour, taken from the cycle diagram (fig. 1). [kJ/kg]
- v_g = specific volume of the compressed gas at the separator inlet (Fig. 1). [m³/kg]

Checking the gas speed, with reference to the cross section of oil separator, the following is obtained:

$$v = \frac{Q}{S} \quad [\text{m/s}]$$

with:

- S = gross section of separator body [m²]

INSTALLATION

The oil separators 5520 and 5540 should be installed on the discharge line between the compressor and the condenser, mounted exclusively in a vertical position and as close to the compressor as possible.

To prevent the return of the refrigerant liquid from

condenser to the oil separator, it's advisable to install a check valve between the condenser and oil separator during a shut-down period.

The oil separator performs best when operating at or near the compressor discharge temperature. If possible, avoid installation in locations that could cause the body of the separator to be cooled, causing condensation of the refrigerant. If this is not possible, it is advisable to equip the separator with appropriate solutions (insulation, strap heater, or other) to prevent the refrigerant in the system from condensing.

Before the oil separator is installed, be it a 5520 or a 5540, add the amount of lubricant specified in the table as an initial oil charge. It is very important to carry out this oil pre-charge correctly for a good operation of the separator and to avoid damaging the float mechanism. Always use the same type of lubricant that is in the compressor crankcase.

Based on the layout of refrigerating system, connect the oil return line to one of the following positions:

- Directly to the compressor crankcase
- To the suction line upstream of the compressor or upstream of the receiver, if present
- To the oil reservoir if the system has a centralised oil control system and an oil distribution system to compressors

It is recommended that a liquid indicator be installed in the oil return line, in order to check the correct working of the oil separator.

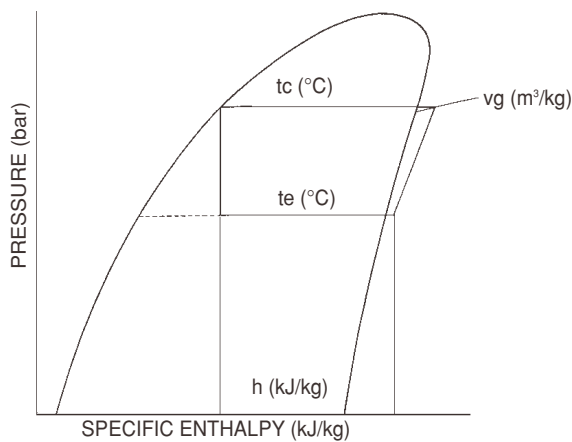

■ Fig. 1

TABLE 1: General characteristics of oil separators

Catalogue Number	Solder Connections				Couple of solder connections IN / OUT			Oil connection [SAE Flare]	Oil addition [kg]	Max. differential pressure [bar]	PS [bar]	TS [°C]		TA [°C]		Volume [l]	Risk Category according to PED Recast
	ODS		ODM		Catalogue Number	ODS (1)						min.	max.	min.	max.		
	Ø [in.]	Ø [mm]	Ø [in.]	Ø [mm]		Ø [in.]	Ø [mm]										
5540/4	1/2"	–	5/8"	16	–	–	–	1/4"	0,4 / 0,5	30	45	–10	+130	–20	+50	2,40	I
5540/5	5/8"	16	3/4"	–												3,03	
5540/7	7/8"	–	1"	–												3,52	
5540/9	1.1/8"	–	1.3/8"	35												7,00	
5540/11	1.3/8"	35	1.5/8"	–												–	
5540/13	1.5/8"	–	–	–				–									
5540/M42	–	42	–	–				–									
5540/17	2.1/8"	54	–	–				–									
5520/C	–				5590/5	5/8"	16	1/4"	0,4 / 0,5	30	45	–10	+130	–20	+50	2,95	I
	–				5590/7	7/8"	–									3,45	
5520/D	–				5590/9	1.1/8"	–									3,45	
	–				5590/11	1.3/8"	35									3,45	
5520/E	–				5590/13	1.5/8"	–									3,45	
	–				5590/M42	–	42									–	

(1) : The dimensions of the separator's connections must agree with the discharge diameter of the compressor

TABLE 2: Dimensions and weights of oil separators

Catalogue Number		Solder Connections		Dimensions [mm]						Weight [g]
Separator	Connections	ODS		$\varnothing D_1$	$\varnothing D_2$	H_1	H_2	H_3	H_4	
		\varnothing [in.]	\varnothing [mm]							
5540/4	-	1/2"	-	123	-	17,5	-	-	280	4200
5540/5		5/8"	16						367	4960
5540/7		7/8"	-						428	5030
5540/9		1.1/8"	-						471	5835
5540/11		1.3/8"	35	481					5800	
5540/13		1.5/8"	-	481					10000	
5540/M42		-	42	481					10460	
5540/17		2.1/8"	54	163,5					17,5	17,5
5520/C	5590/5	5/8"	16	121	149	17,5	336	61	397	6980
	5590/7	7/8"	-							
5520/D	5590/9	1.1/8"	-	121	149	17,5	391	67	458	7760
	5590/11	1.3/8"	35							
5520/E	5590/13	1.5/8"	-	121	149	17,5	391	92	483	7680
	5590/M42	-	42							

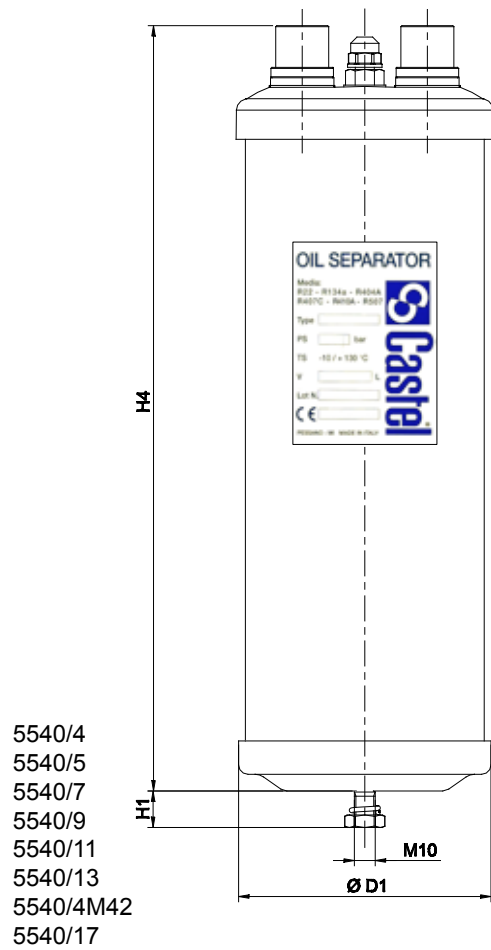
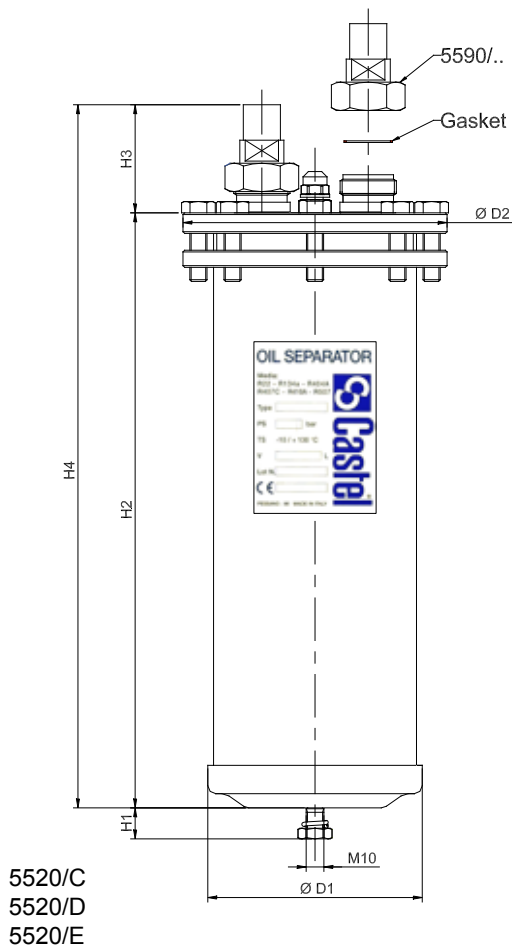

TABLE 3: Refrigerant flow capacity

Catalogue Number	Catalogue Number of solder connections	R134a					
		Condensing temperature [°C]					
		+40			+50		
		Evaporating temperature [°C]			Evaporating temperature [°C]		
		-20	-10	+5	-20	-10	+5
5540/4	-	5,4	5,7	6,3	6,2	6,7	7,3
5540/5		10,7	11,5	12,6	12,4	13,3	14,7
5540/7		13,4	14,4	15,7	15,5	16,6	18,4
5540/9		16,1	17,2	18,8	18,6	20,0	22,0
5540/11		18,8	20,1	22,0	21,7	23,3	15,7
5540/13		30,6	32,7	35,8	35,3	37,9	41,9
5540/M42							
5540/17		38,3	40,9	44,8	44,1	47,4	52,4
5520/C	5590/5	10,7	11,5	12,6	12,4	13,3	14,7
	5590/7	13,4	14,4	15,7	15,5	16,6	18,4
5520/D	5590/9	16,1	17,2	18,8	18,6	20,0	22,0
	5590/11	18,8	20,1	22,0	21,7	23,3	15,7
5520/E	5590/13	21,5	23,0	25,1	24,7	26,6	29,4
	5590/M42						

TABLE 3: Refrigerant flow capacity

Catalogue Number	Catalogue Number of solder connections	R22									
		Condensing temperature [°C]									
		+40					+50				
		Evaporating temperature [°C]					Evaporating temperature [°C]				
		-40	-30	-20	-10	+5	-40	-30	-20	-10	+5
5540/4	-	6,0	6,5	7,0	7,5	8,2	6,7	7,3	7,9	8,5	9,3
5540/5		12,0	13,0	13,9	14,9	16,4	13,4	14,6	15,8	16,9	18,6
5540/7		15,0	16,2	17,4	18,6	20,5	16,8	18,2	19,7	21,2	23,3
5540/9		18,0	19,5	20,9	22,4	14,6	20,2	21,9	23,7	25,4	28,0
5540/11		21,0	22,7	24,4	26,1	28,7	23,5	25,5	27,6	29,6	32,6
5540/13		34,2	37,0	39,7	42,5	46,8	38,3	41,6	45,0	48,3	53,1
5540/M42											
5540/17		42,8	46,2	49,6	53,1	58,5	47,9	52,0	56,2	60,4	66,4
5520/C	5590/5	12,0	13,0	13,9	14,9	16,4	13,4	14,6	15,8	16,9	18,6
	5590/7	15,0	16,2	17,4	18,6	20,5	16,8	18,2	19,7	21,2	23,3
5520/D	5590/9	18,0	19,5	20,9	22,4	14,6	20,2	21,9	23,7	25,4	28,0
	5590/11	21,0	22,7	24,4	26,1	28,7	23,5	25,5	27,6	29,6	32,6
5520/E	5590/13	24,0	25,9	27,9	29,8	32,8	26,9	29,2	31,5	33,9	37,3
	5590/M42										

(1) : Refrigerant flow capacity with overheating values of vapour sucked by compressor of 10 °C. No liquid subcooling.

Continued

Maximum pressure drop of 0,15 bar

TABLE 3: Refrigerant flow capacity

Catalogue Number	Catalogue Number of solder connections	R404A									
		Condensing temperature [°C]									
		+40					+50				
		Evaporating temperature [°C]					Evaporating temperature [°C]				
		-40	-30	-20	-10	+5	-40	-30	-20	-10	+5
5540/4	-	6,6	7,2	7,9	8,5	9,4	6,8	7,6	8,3	9,1	10,2
5540/5		13,2	14,5	15,8	17,1	18,8	13,6	15,1	16,7	18,2	20,4
5540/7		16,5	18,1	19,7	21,3	23,5	17,0	18,9	20,8	22,8	25,5
5540/9		19,8	21,7	23,7	25,6	28,2	20,3	22,7	25,0	27,3	30,6
5540/11		23,1	25,3	27,6	29,9	32,9	23,7	26,5	29,1	31,9	35,7
5540/13		37,6	41,2	45,0	18,6	53,6	38,7	43,1	47,5	52,0	58,2
5540/M42											
5540/17			47,0	51,5	56,3	60,8	67,0	48,3	53,9	59,4	65,0
5520/C	5590/5	13,2	14,5	15,8	17,1	18,8	13,6	15,1	16,7	18,2	20,4
	5590/7	16,5	18,1	19,7	21,3	23,5	17,0	18,9	20,8	22,8	25,5
5520/D	5590/9	19,8	21,7	23,7	25,6	28,2	20,3	22,7	25,0	27,3	30,6
	5590/11	23,1	25,3	27,6	29,9	32,9	23,7	26,5	29,1	31,9	35,7
5520/E	5590/13	26,4	28,9	31,6	34,1	37,6	27,1	30,3	33,3	36,5	40,8
	5590/M42										

TABLE 3: Refrigerant flow capacity

Catalogue Number	Catalogue Number of solder connections	R407C									
		Condensing temperature [°C]									
		+40					+50				
		Evaporating temperature [°C]					Evaporating temperature [°C]				
		-40	-30	-20	-10	+5	-40	-30	-20	-10	+5
5540/4	-	7,0	7,6	8,2	8,8	9,7	7,6	8,4	9,1	9,8	10,9
5540/5		14,0	15,2	16,4	17,6	19,4	15,3	16,7	18,2	19,6	21,8
5540/7		17,5	19,0	20,5	22,0	24,3	19,1	20,9	22,7	24,5	27,3
5540/9		21,0	22,8	24,6	26,4	29,1	22,9	25,1	27,3	29,4	32,7
5540/11		24,4	26,6	28,7	30,8	34,0	26,7	29,3	31,8	34,3	38,2
5540/13		39,8	43,4	46,8	50,2	55,3	43,5	47,7	51,8	55,9	62,2
5540/M42											
5540/17			49,8	54,2	58,5	62,7	69,1	54,4	59,7	64,8	69,9
5520/C	5590/5	14,0	15,2	16,4	17,6	19,4	15,3	16,7	18,2	19,6	21,8
	5590/7	17,5	19,0	20,5	22,0	24,3	19,1	20,9	22,7	24,5	27,3
5520/D	5590/9	21,0	22,8	24,6	26,4	29,1	22,9	25,1	27,3	29,4	32,7
	5590/11	24,4	26,6	28,7	30,8	34,0	26,7	29,3	31,8	34,3	38,2
5520/E	5590/13	27,9	30,4	32,8	35,2	38,8	30,5	33,5	36,4	39,2	43,6
	5590/M42										

(1) : Refrigerant flow capacity with overheating values of vapour sucked by compressor of 10 °C. No liquid subcooling.

Continued

Maximum pressure drop of 0,15 bar

TABLE 3: Refrigerant flow capacity

Catalogue Number	Catalogue Number of solder connections	R410A					
		Condensing temperature [°C]					
		+40			+50		
		Evaporating temperature [°C]			Evaporating temperature [°C]		
		-20	-10	+5	-20	-10	+5
5540/4	-	10,1	10,9	12,0	11,0	11,8	13,2
5540/5		20,2	21,7	23,9	22,0	23,6	26,4
5540/7		25,3	27,1	29,9	27,5	29,5	32,9
5540/9		30,3	32,6	35,9	33,0	35,4	39,5
5540/11		35,4	38,0	41,9	38,5	41,3	46,1
5540/13		-	-	-	-	-	-
5540/M42		-	-	-	-	-	-
5540/17		-	-	-	-	-	-
5520/C	5590/5	20,2	21,7	23,9	22,0	23,6	26,4
	5590/7	25,3	27,1	29,9	27,5	29,5	32,9
5520/D	5590/9	30,3	32,6	35,9	33,0	35,4	39,5
	5590/11	35,4	38,0	41,9	38,5	41,3	46,1
5520/E	5590/13	40,4	43,4	47,9	4,0	47,2	52,7
	5590/M42						

(1) : Refrigerant flow capacity with overheating values of vapour sucked by compressor of 10 °C. No liquid subcooling.

Maximum pressure drop of 0,15 bar

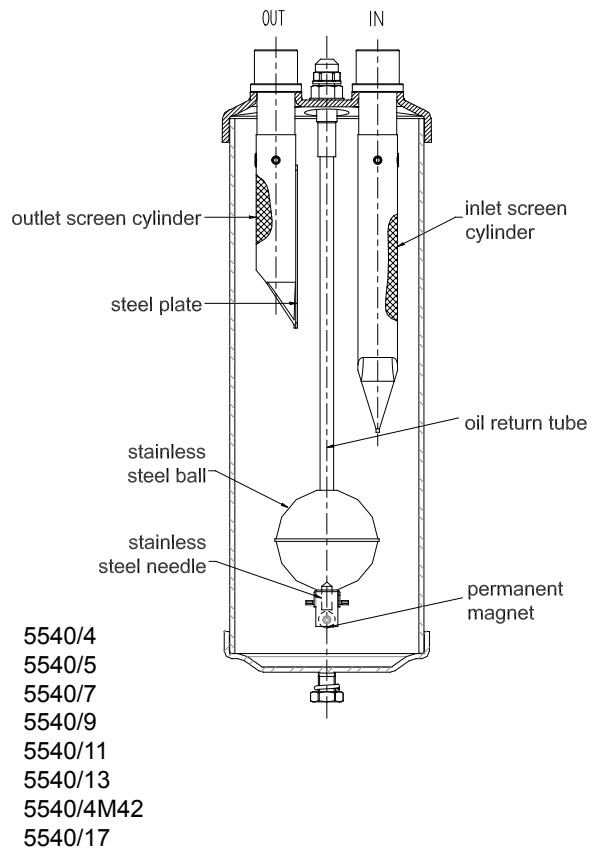
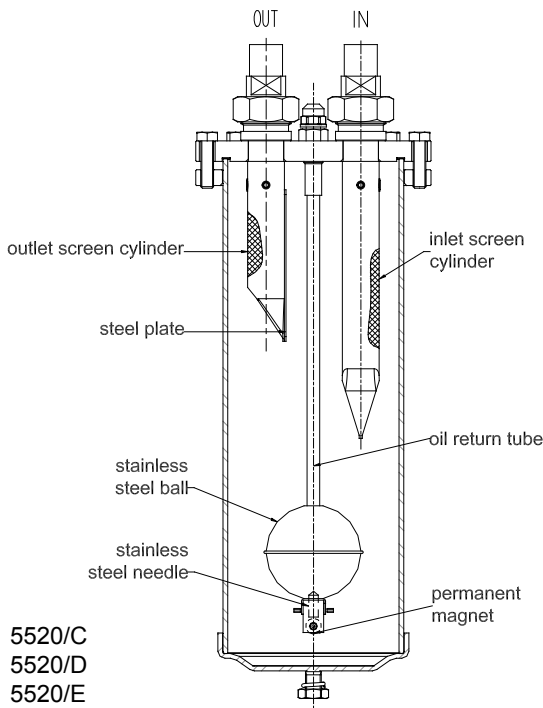

www.castel.it



ed. 001-CO-ENG

Castel can accept no responsibility for any errors or changes in the catalogues, handbooks, brochures and other printed material. Castel reserves the right to make changes and improvements to its products without notice. All trademarks mentioned are the property of their respective owners.

The name and Castel logotype are registered trademarks of Castel Srl.
All rights reserved.

Castel Srl - Via Provinciale 2-4 - 20060 Pessano con Bornago - MI