

Application guidelines

Danfoss scrolls, **H-Series** Residential and light commercial

50 - 60 Hz - R407C - R22 - R410A



Scroll compression principle	5
Scroll compressor components.....	5
The scroll compression process.....	6
H-series color.....	6
Compressor model designation	7
Nomenclature	7
Label.....	7
Technical specifications	8
60-Hz data *	8
50-Hz data *	9
Dimensions	10
HRM032-034-038-040-042 / HRP034-038-040-042 / HRH029-031-032-034-036-038 /	
HRM-045-047 / HRP-045-047 / HRH039-040.....	10
HRM048-051-054-058-060 / HLM068-072-075-078-081 / HRP048-051-054-058-060 /	
HLP068-072-075-078-081 / HRH041-044-049-051-054-056 / HLH061-068 / HLJ072-075-083	11
HCM/HCP 094-109-120.....	12
HCJ090-105-120.....	13
HCJ091-106-121	14
HLH061-HLJ072-HLJ083.....	15
Electrical data, connections and wiring.....	16
Motor voltage	16
Wiring connections.....	16
IP rating	17
LRA (Locked Rotor Amp)	17
MCC (Maximum Continuous Current).....	17
Winding resistance.....	17
Electrical connections	17
Nominal capacitor value and relays.....	18
Internal motor protection.....	18
Phase sequence and reverse rotation protection.....	18
Voltage imbalance	18
Approvals and certifications.....	19
Approvals and certificates	19
Pressure equipment directive 97/23/EC.....	19
Low voltage directive 73/23/EC, 93/68/EC	19
Internal free volume	19
Operating conditions	20
Refrigerant and lubricants.....	20
Motor supply.....	21
Compressor ambient temperature.....	21
Application envelope.....	21
R22, R407C Model variation T.....	21
R410A Model variation T	22
R22, R410A Model variation U.....	22
Maximum discharge gas temperature.....	22
High and low pressure protection.....	24
On/off cycling (cycle rate limit).....	24

System design recommendations	25
General	25
Essential piping design considerations	25
Refrigerant charge limit	26
Crankcase heater.....	28
Reversible heat pump systems	29
Loss of charge protection	29
Tandem.....	29
Oil level checking and top-up.....	29
Minimum sump superheat.....	29
High pressure ratio.....	29
Phase sequence and reverse rotation protection.....	29
Internal motor protection.....	30
Preventing liquid flood back	30
Testing for excessive liquid flood back	30
Split unit cooling mode.....	30
Water utilising systems.....	30
Sound and vibration management.....	31
Starting sound level.....	31
Running sound level.....	31
Stopping sound level	31
Sound generation in a refrigeration system / air conditioning system	31
Compressor sound radiation	31
Mechanical vibrations	32
Gas pulsation.....	32
Installation	33
System cleanliness.....	33
Compressor handling and storage.....	33
Compressor mounting.....	33
Compressor holding charge	33
Tube brazing procedure	33
Brazing material	33
Vacuum evacuation and moisture removal	34
Liquid line filter driers	35
Refrigerant charging.....	35
Insulation resistance and dielectric strength	35
Compressor replacement after motor burn out.....	35
Ordering information and packaging.....	36
Packaging	36
Packaging details	36
R22 Single pack	37
R22 Industrial pack.....	38
R407C Single pack.....	39
R407C Industrial pack.....	40
R410A Single pack.....	41
R410A Industrial pack	42
Spare parts & accessories.....	43
Run capacitors for PSC wiring	43
Start capacitors and starting relay for CSR wiring	43
Rotolock adaptor set	43
Rotolock adaptor	44
Crankcase heater.....	44
Discharge temperature protection	44
Lubricant.....	44
Mounting hardware.....	45

Scroll compressor components

The motor stator is rigidly attached to the shell. The rotor is shrink-fit onto the eccentric shaft. The shaft is supported by two bearings, one in the crankcase and the second below the motor.

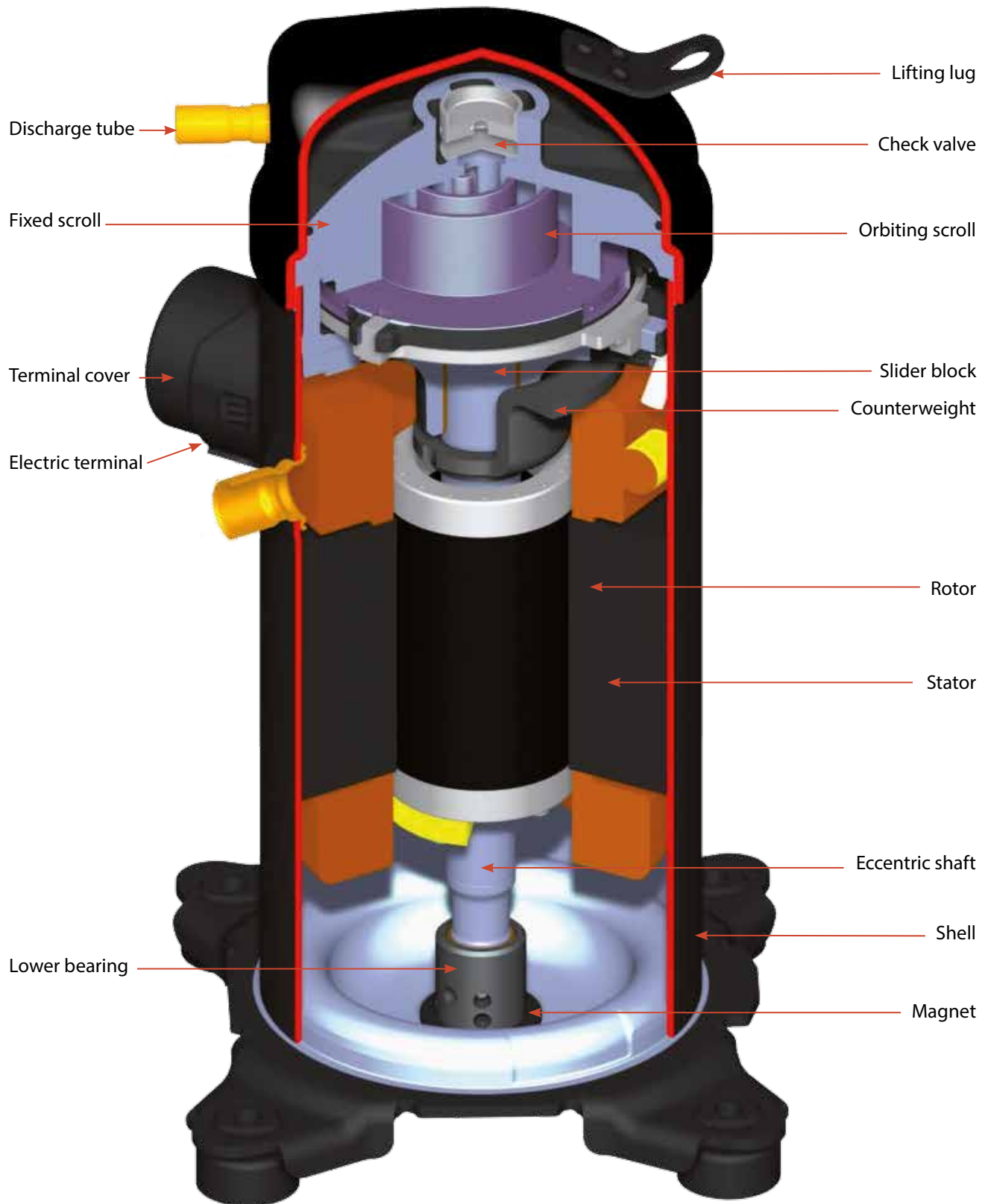

The scroll compression process

The entire scroll compression process is illustrated below. The centre of the orbiting scroll traces a circular path around the centre of the fixed scroll. This movement creates compression pockets between the two scroll elements.

Low pressure suction gas is trapped within each crescent-shaped pocket as it forms; continuous motion of the orbiting scroll serves to seal the pocket, which decreases in volume as the

pocket moves towards the centre of the scroll set, with corresponding increase in gas pressure. Maximum compression is achieved, as the pocket reaches the discharge port at the centre.

Scroll compression is a continuous process: when one pocket of gas is being compressed during the second orbit, another gas quantity enters a new pocket formed at the periphery, and simultaneously, another is being discharged.

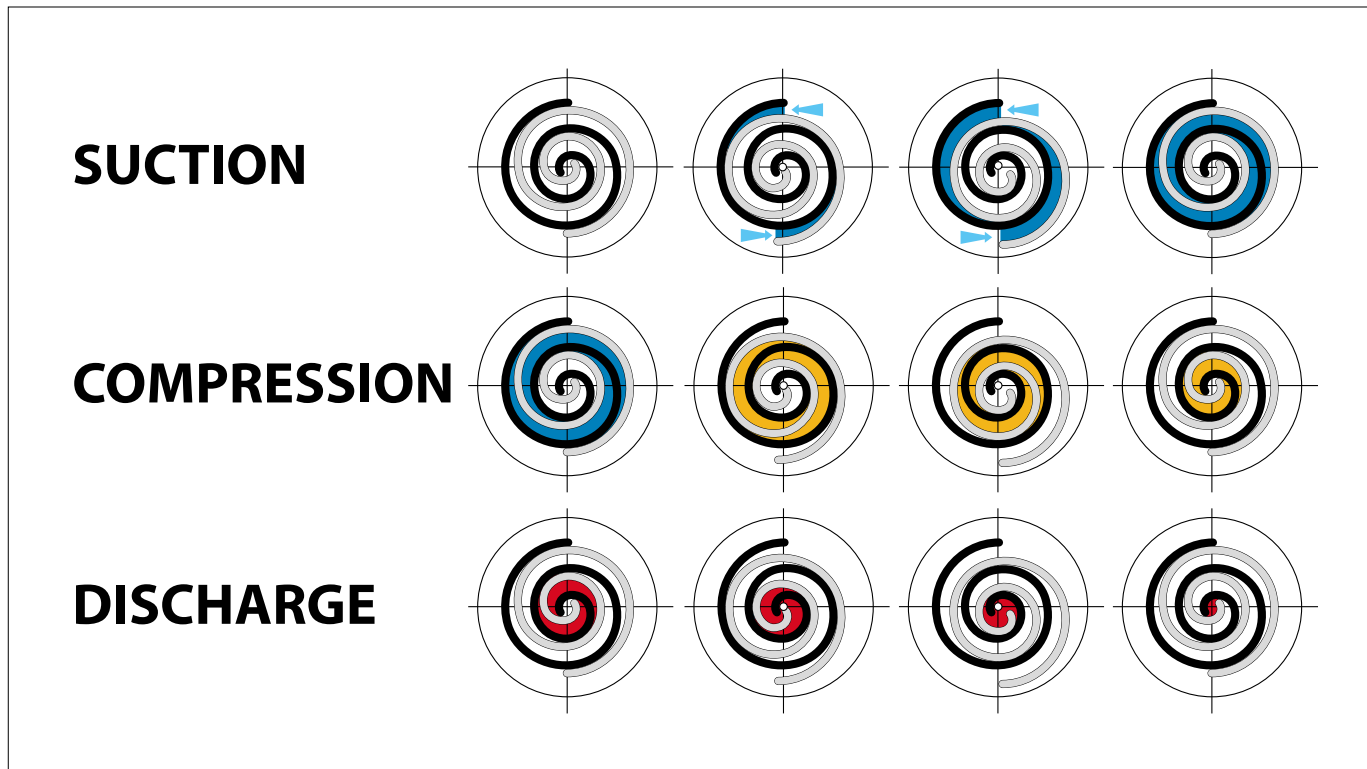

Danfoss scroll compressors are manufactured using the most advanced machining, assembly, and process control techniques. In design of both the compressor and the factory, very high

standards of reliability and process control were first priority. The result is a highly efficient product with the highest reliability obtainable, and a low sound level.

H-series color

The H-series compressors can be black or blue depending on the production site.

Nomenclature

Type	Size	Motor	Features
HRH	036	U1L	P6

Application: _____
H: high temperature / air conditioning

Family: _____
C: commercial scroll
R: residential scroll (new platform)
L: light commercial scroll (new platform)

Refrigerant & lubricant: _____
M: R22, alkylbenzene lubricant
P: R407C, PVE lubricant
H: R410A, PVE lubricant
J: R410A, PVE lubricant

Nominal capacity: _____
 In thousand Btu/h at 60 Hz,
 ARI conditions

Model variation _____
T: design optimized for 45/130°F
U: design optimized for 45/100°F

Other features

	Oil sight glass	Oil equalization	Oil drain	LP gauge port	Gas equalization port
6	None	None	None	None	None
7	Threaded	None	None	None	None
8	None	Brazed	None	None	Brazed
T	None	Screw	Schrader	None	None

Other features

Oil sight glass

Oil equalization

Oil drain

LP gauge port

Gas equalization port

6 None None None None None

7 Threaded None None None None

8 None Brazed None None Brazed

T None Screw Schrader None None

Tubing and electrical connections

P: brazed connections, spade terminals

C: brazed connections, screw terminals

Motor protection

L: internal motor protection

Motor voltage code

1: 208-230V/1~/60 Hz

2: 200-220V/3~/50Hz & 208-230V/3~/60 Hz

4: 380-415V/3~/50 Hz & 460V/3~/60 Hz

5: 220-240V/1~/50 Hz

7: 500V/3~/50 Hz & 575V/ 3~/60 Hz

9: 380V/3~/60 Hz

Version T compressors are built with a threaded oil equalization port to be used with our variable speed compressors range VZH.

Label

Danfoss Commercial Compressors

Model no. HRH038U5LP6 MADE IN USA

Tech no. XGE380HA01 220 - 240 V 1~ 50 Hz

Serial no. S0309K15172 Run Cap: 60 µF ± 370 V

LR: 103.0 A

Lubricant: POE - 36oz / 1.1L

Ref No: GC06RQ001

CE, UL, Performer

PROTECTED BY DOMESTIC AND FOREIGN PATENTS

WARNING

Refer to service instructions. Overheating could result without injury or death.

1. **ELECTRICAL SHOCK** - Terminal cover must be in place and security retained whenever power is applied to this compressor. Always use the correct air conditioning equipment for high voltage and other dangers.

2. **OVERPRESSURE** - Remove pressure before servicing wearing safety goggles. Use all service points to relieve pressure.

3. **FIRE HAZARD** - The hot oil bath to remove components of this unit may use flammable lubricant.

CAUTION

1. Use proper conductance only.

2. Use RVC wire for ampacity determination.

3. Terminal connections must meet the manufacturer's listed performance standards. Wires must match terminal size, length and depth of terminal box cover and gasket.

4. Use this equipment on a grounded system only.

AVERTISSEMENT

Le réfrigérant toxique ou explosif doit être respecté. Le maniement des instructions de service peut entraîner des blessures graves.

1. **ELECTROCUTION** - Le couvercle du bornier doit être en place et les connecteurs doivent être correctement installés. Toujours utiliser l'équipement de conditionnement d'air approprié pour les hautes tensions et d'autres dangers.

2. **HAUTE PRESSION** - Avant d'intervenir sur le circuit, réduire la pression interne et porter des lunettes de protection.

3. **DANGER D'INCENDIE** - Utilisez un bain d'huile pour retirer le condensat. L'huile peut être inflammable.

ATTENTION

1. Utilisez le compresseur avec des conducteurs adéquats.

2. Utilisez un fil AWG d'ampacité supportée ou inférieure au RVC.

3. Respectez les indications placées à l'intérieur du boîtier pour le raccordement des bornes du compresseur.

4. N'utilisez pas ce réfrigérant à la fois.

Application Guidelines Technical specifications

60-Hz data *

	Model	Nominal	Nominal cooling capacity		Power input	A max.	Efficiency			Swept	Displacement	Oil charge	Net weight
		Cap. 60 Hz	W	Btu/h	kW	A	COP	W/W	EER Btu/h/W	cu.in/rev	cu.ft/h	oz	lbs
R22	HRM032U4	2.7	9 320	31 790	2.94	9.5	3.17	10.8	2.66	323	36	71	
	HRM034U4	2.8	9 810	33 480	3.07	9.5	3.20	10.9	2.82	343	36	71	
	HRM038U4	3.2	11 130	37 980	3.39	10.0	3.28	11.2	2.82	343	36	71	
	HRM040U4	3.3	11 720	39 980	3.57	10.0	3.28	11.2	3.32	403	36	71	
	HRM042U4	3.5	12 300	41 980	3.75	11.0	3.28	11.2	3.49	424	36	71	
	HRM045U4	3.8	13 180	44 980	4.01	12.0	3.28	11.2	3.75	456	45	71	
	HRM047U4	3.9	13 920	47 490	4.22	12.0	3.30	11.3	3.91	475	45	71	
	HRM048U4	4.0	13 830	47 180	4.25	12.5	3.25	11.1	3.93	477	53	86	
	HRM051T4	4.3	15 030	51 270	4.46	13.0	3.37	11.5	4.20	510	53	86	
	HRM051U4	4.3	15 030	51 280	4.46	13.0	3.37	11.5	4.20	510	53	86	
	HRM054U4	4.5	15 730	53 680	4.62	13.1	3.40	11.6	4.45	541	53	90	
	HRM058U4	4.8	16 930	57 780	5.02	15.0	3.37	11.5	4.77	580	53	90	
	HRM060T4	5.0	17 490	59 670	5.14	15.0	3.40	11.6	4.94	600	53	90	
	HRM060U4	5.0	17 490	59 680	5.19	15.0	3.37	11.5	4.94	600	53	90	
	HLM068T4	5.7	20 190	68 880	5.94	15.0	3.40	11.6	5.68	690	53	90	
	HLM072T4	6.0	21 330	72 770	6.27	15.0	3.40	11.6	6.02	732	53	90	
	HLM075T4	6.3	22 120	75 480	6.45	16.0	3.43	11.7	6.27	762	53	90	
HLM081T4	6.8	23 880	81 470	6.96	17.0	3.43	11.7	6.77	823	53	90		
HCM094T4	7.8	27 690	94 470	8.07	21.0	3.43	11.7	7.69	934	90	104		
HCM109T4	9.1	32 020	109 270	9.33	24.0	3.43	11.7	9.08	1104	90	104		
HCM120T4	10.0	34 950	119 260	10.22	25.0	3.42	11.7	9.91	1204	90	104		
R407C	HRP051T4	4.3	14 380	49080	4.46	13.0	3.23	11.0	4.20	510	53	86	
R410A	HRH029U4	2.4	8 500	29 000	2.84	10.0	2.99	10.2	1.70	206	36	71	
	HRH031U4	2.6	9 080	30 990	3.04	10.0	2.99	10.2	1.82	221	36	71	
	HRH032U4	2.7	9 380	31 990	3.10	10.0	3.02	10.3	1.87	227	36	71	
	HRH034U4	2.8	10 110	34 510	3.38	10.0	2.99	10.2	2.03	245	36	71	
	HRH036U4	3.0	10 370	35 390	3.47	10.0	2.99	10.2	2.12	258	36	71	
	HRH038U4	3.2	11 100	37 890	3.79	12.0	2.93	10.0	2.23	271	36	86	
	HRH040U4	3.3	12 160	41 490	4.03	12.0	3.02	10.3	2.42	293	45	86	
	HRH041U4	3.3	12 100	41 300	4.05	12.5	2.99	10.2	2.40	293	53	86	
	HRH044U4	3.7	13 010	44 390	4.31	13.5	3.02	10.3	2.60	316	53	86	
	HRH049U4	4.1	14 360	48 990	4.66	13.5	3.08	10.5	2.89	351	53	86	
	HRH051U4	4.3	15 180	51 780	4.84	13.0	3.14	10.7	3.01	366	53	90	
	HRH054U4	4.5	15 970	54 480	5.14	15.0	3.11	10.6	3.18	386	53	90	
	HRH056U4	4.7	16 670	56 880	5.36	15.0	3.11	10.6	3.30	401	53	90	
	HLH061T4	5.1	18 050	61 580	5.70	15.0	3.17	10.8	3.53	428	53	90	
	HLH068T4	5.7	20 130	68 670	6.30	19.0	3.20	10.9	3.93	477	53	90	
	HLJ072T4	6.0	21 240	72 500	6.65	19.0	3.19	10.9	4.15	504	53	90	
	HLJ075T4	6.3	22 320	76 190	6.86	18.0	3.25	11.1	4.32	525	53	90	
HLJ083T4	6.9	24 340	83 090	7.55	19.0	3.22	11.0	4.77	579	53	90		
H CJ090T4	7.5	26 810	91 500	8.47	19.0	3.16	10.8	5.30	644	90	97		
H CJ091T4	7.5	27 140	92 600	8.37	17.0	3.24	11.07	5.30	644	83	108		
H CJ105T4	8.8	31 170	106 390	9.75	25.0	3.20	10.9	6.20	754	90	97		
H CJ106T4	8.8	31 670	108 050	9.67	20.0	3.28	11.18	6.20	754	83	108		
H CJ120T4	10.0	35 620	121 600	11.15	27.0	3.20	10.9	7.10	863	90	97		
H CJ121T4	10.0	35 940	122 620	11.07	21.0	3.25	11.08	7.10	863	83	108		

TR = Ton of Refrigeration
 COP = Coefficient Of Performance
 EER = Energy Efficiency Ratio

*: ARI standard rating conditions,
 460V / 3ph / 60Hz

Evaporating temperature : 45 °F
 Condensing temperature: 130 °F
 Superheat: 20 °F
 Sub-cooling: 15 °F

Subject to modification without prior notification

For full data details and capacity tables refer to Online Datasheet Generator : www.danfoss.com/odsg

Application Guidelines Technical specifications

50-Hz data *

Model	Nominal Cap 60 Hz	Nominal cooling capacity		Power input	A max.	Efficiency		Swept volume	Displacement	Oil charge	Net weight	
	TR	W	Btu/h	kW	A	COP	W/W EER	Btu/h/W	cu.in/rev	cu.ft/h	oz	lbs
R22	HRM032U4	2.7	7 850	26 790	2.55	9.5	3.08	10.5	2.66	268	36	71
	HRM034U4	2.8	8 350	28 490	2.66	9.5	3.14	10.7	2.82	284	36	71
	HRM038U4	3.2	9 240	31 520	2.94	10.0	3.14	10.7	2.82	284	36	71
	HRM040U4	3.3	9 710	33 120	2.98	10.0	3.26	11.1	3.32	334	36	71
	HRM042U4	3.5	10 190	34 770	3.13	11.0	3.26	11.1	3.49	351	36	71
	HRM045U4	3.8	10 940	37 310	3.45	12.0	3.17	10.8	3.75	378	45	71
	HRM047U4	3.9	11 500	39 250	3.57	12.0	3.23	11.0	3.91	394	45	71
	HRM048U4	4.0	11 510	39 270	3.57	12.5	3.23	11.0	3.93	396	53	86
	HRM051T4	4.3	12 390	42 280	3.67	13.0	3.37	11.5	4.20	423	53	86
	HRM051U4	4.3	12 800	43 690	3.83	13.0	3.34	11.4	4.20	423	53	86
	HRM054U4	4.5	13 390	45 680	3.97	13.1	3.37	11.5	4.45	448	53	90
	HRM058U4	4.8	14 340	48 930	4.25	15.0	3.37	11.5	4.77	480	53	90
	HRM060T4	5.0	14 570	49 720	4.28	15.0	3.40	11.6	4.94	498	53	90
	HRM060U4	5.0	14 820	50 580	4.40	15.0	3.37	11.5	4.94	498	53	90
	HLM068T4	5.7	16 880	57 580	5.00	15.0	3.37	11.5	5.68	572	53	90
	HLM072T4	6.0	17 840	60 870	5.29	15.0	3.37	11.5	6.02	607	53	90
	HLM075T4	6.3	18 430	62 880	5.37	16.0	3.43	11.7	6.27	631	53	90
	HLM081T4	6.8	19 890	67 880	5.80	17.0	3.43	11.7	6.77	682	53	90
HCM094T4	7.8	23 060	78 670	6.80	21.0	3.39	11.6	7.69	774	90	104	
HCM109T4	9.1	26 690	91 070	7.77	24.0	3.43	11.7	9.08	914	90	104	
HCM120T4	10.0	29 130	99 390	8.51	25.0	3.42	11.7	9.91	998	90	104	
R407C	HRP034T4	2.8	7 940	27 080	2.68	9.5	2.96	10.1	2.82	283	36	71
	HRP038T4	3.2	8 840	30 150	2.82	11.0	3.14	10.7	3.15	317	36	71
	HRP040T4	3.3	9 110	31 080	3.14	11.5	2.90	9.9	3.32	334	36	71
	HRP042T4	3.5	9 580	32 680	3.30	10.0	2.90	9.9	3.49	351	36	71
	HRP045T4	3.8	10 810	36 890	3.58	12.0	3.02	10.3	3.75	378	45	71
	HRP047T4	3.9	11 130	37 980	3.69	12.0	3.02	10.3	3.91	394	45	71
	HRP048T4	4.0	11 100	37 880	3.35	12.0	3.31	11.3	3.93	396	53	86
	HRP051T4	4.3	12 120	41 370	3.83	13.0	3.17	10.8	4.20	423	53	86
	HRP054T4	4.5	12 570	42 880	3.97	12.5	3.17	10.8	4.44	447	53	90
	HRP058T4	4.8	13 470	45 970	4.25	14.0	3.17	10.8	4.77	480	53	90
	HRP060T4	5.0	13 860	47 280	4.26	15.0	3.25	11.1	4.94	498	53	90
	HLP068T4	5.7	15 700	53 560	5.10	15.0	3.08	10.5	5.68	572	53	90
	HLP072T4	6.0	16 810	57 350	5.16	15.0	3.26	11.1	6.02	606	53	90
	HLP075T4	6.3	18 040	61 550	5.54	16.0	3.26	11.1	6.27	631	53	90
	HLP081T4	6.8	18 600	63 470	5.66	17.0	3.28	11.2	6.77	682	53	90
	HCP094T4	7.8	21 590	73 660	6.63	21.0	3.26	11.1	7.69	774	90	104
	HCP109T4	9.1	25 070	85 550	7.77	24.0	3.23	11.0	9.08	914	90	104
	HCP120T4	10.0	27 370	93 400	8.47	25.0	3.23	11.0	9.91	998	90	104
R410A	HRH029U4	2.4	7 120	24 310	2.43	10.0	2.93	10.0	1.70	171	36	71
	HRH031U4	2.6	7 530	25 710	2.67	10.0	2.82	9.62	1.82	183	36	71
	HRH032U4	2.7	7 670	26 170	2.75	10.0	2.79	9.51	1.87	188	36	71
	HRH034U4	2.8	8 500	29 000	2.90	10.0	2.93	10.0	2.03	203	36	71
	HRH036U4	3.0	8 820	30 110	3.13	10.0	2.82	9.62	2.12	213	36	71
	HRH038U4	3.2	9 250	31 560	3.35	12.0	2.76	9.41	2.23	225	36	86
	HRH040U4	3.3	10 200	34 810	3.58	12.0	2.85	9.72	2.42	244	45	86
	HRH041U4	3.3	10 050	34 300	3.43	12.5	2.93	10.00	2.40	240	53	86
	HRH044U4	3.7	10 830	36 940	3.92	13.5	2.76	9.41	2.60	262	53	86
	HRH049U4	4.1	12 110	41 320	4.04	13.5	2.99	10.22	2.89	291	53	86
	HRH051U4	4.3	12 860	43 890	4.21	13.0	3.05	10.42	3.01	303	53	90
	HRH054U4	4.5	13 340	45 510	4.41	15.0	3.02	10.32	3.18	320	53	90
	HRH056U4	4.7	13 830	47 200	4.58	15.0	3.02	10.31	3.30	333	53	90
	HLH061T4	5.1	15 210	51 880	4.89	15.0	3.11	10.61	3.53	357	53	90
	HLH068T4	5.7	16 880	57 610	5.26	19.0	3.21	10.96	3.93	396	53	90
	HLJ072T4	6.0	17 840	60 900	5.56	19.0	3.21	11.0	4.15	417	53	90
	HLJ075T4	6.3	18 600	63 490	5.77	18.0	3.22	11.0	4.32	435	53	90
	HLJ083T4	6.9	20 420	69 690	6.28	19.0	3.25	11.1	4.77	480	53	90
H CJ090T4	7.5	22 320	76 190	7.19	19.0	3.11	10.6	5.30	534	90	97	
H CJ091T4	7.5	22 380	76 360	7.03	18.0	3.18	10.87	5.30	534	83	108	
H CJ105T4	8.8	26 100	89 090	8.25	25.0	3.16	10.8	6.20	624	90	97	
H CJ106T4	8.8	26 050	88 880	8.07	21.0	3.23	11.01	6.20	624	83	108	
H CJ120T4	10.0	29 610	101 080	9.53	27.0	3.11	10.6	7.10	715	90	97	
H CJ121T4	10.0	29 720	101 400	9.22	22.0	3.22	11.0	7.10	715	83	108	

TR = Ton of Refrigeration
 COP = Coefficient Of Performance
 EER = Energy Efficiency Ratio

*: ARI standard rating conditions,
 400V / 3ph / 50Hz
 Superheat: 20 °F

Evaporating temperature : 45 °F
 Condensing temperature: 130 °F
 Sub-cooling: 15 °F

Subject to modification without prior notification

For full data details and capacity tables refer to Online Datasheet Generator : www.danfoss.com/odsg

HRM032-034-038-040-042 / HRP034-038-040-042 / HRH029-031-032-034-036-038 / HRM-045-047 / HRP-045-047 / HRH039-040

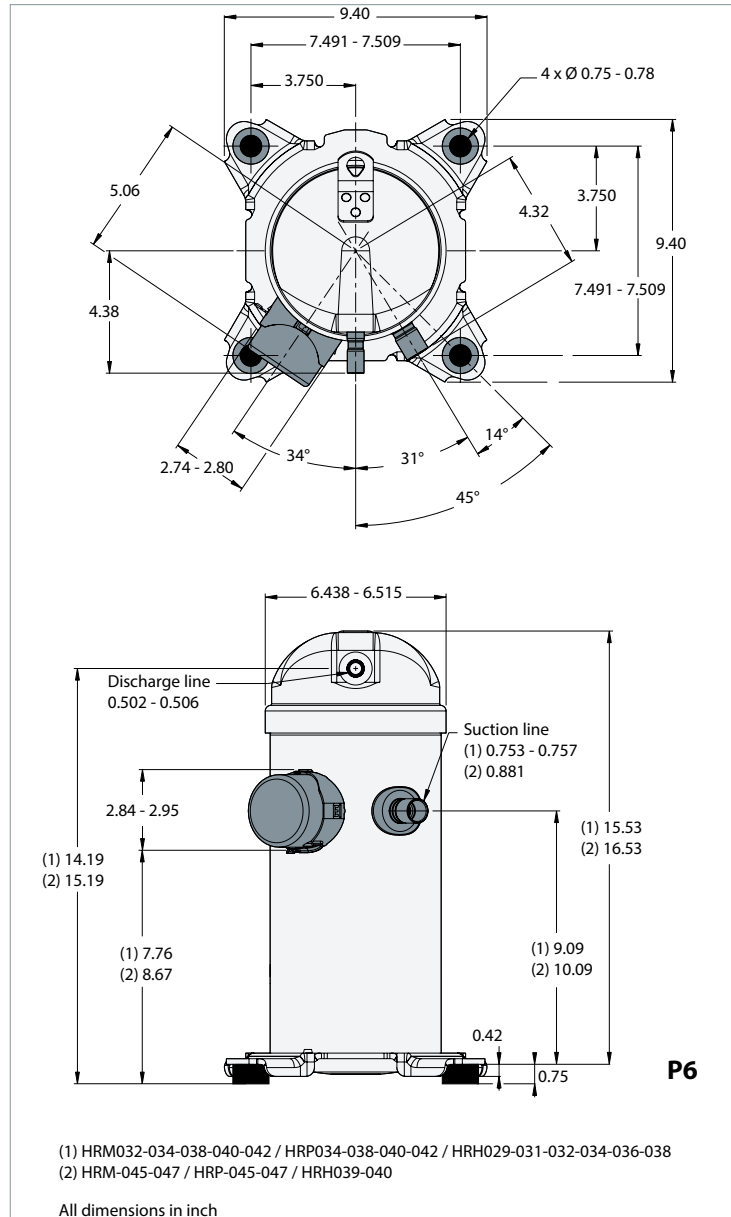

Terminal box

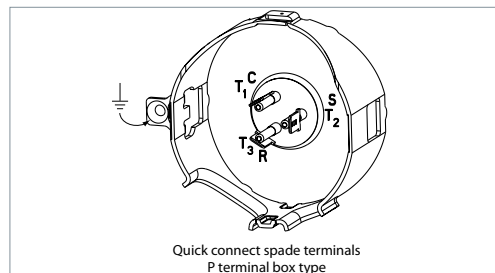

Mounting grommet

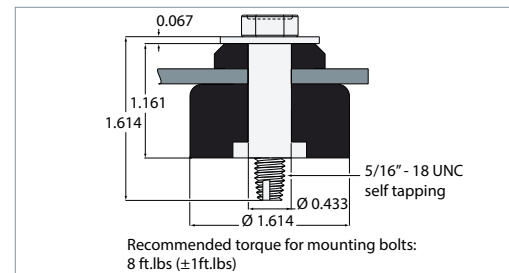

Refer to page 43 for overview of shipped mounting accessories

HRM048-051-054-058-060 / HLM068-072-075-078-081 / HRP048-051-054-058-060 / HLP068-072-075-078-081 / HRH041-044-049-051-054-056 / HLH061-068 / HLJ072-075-083

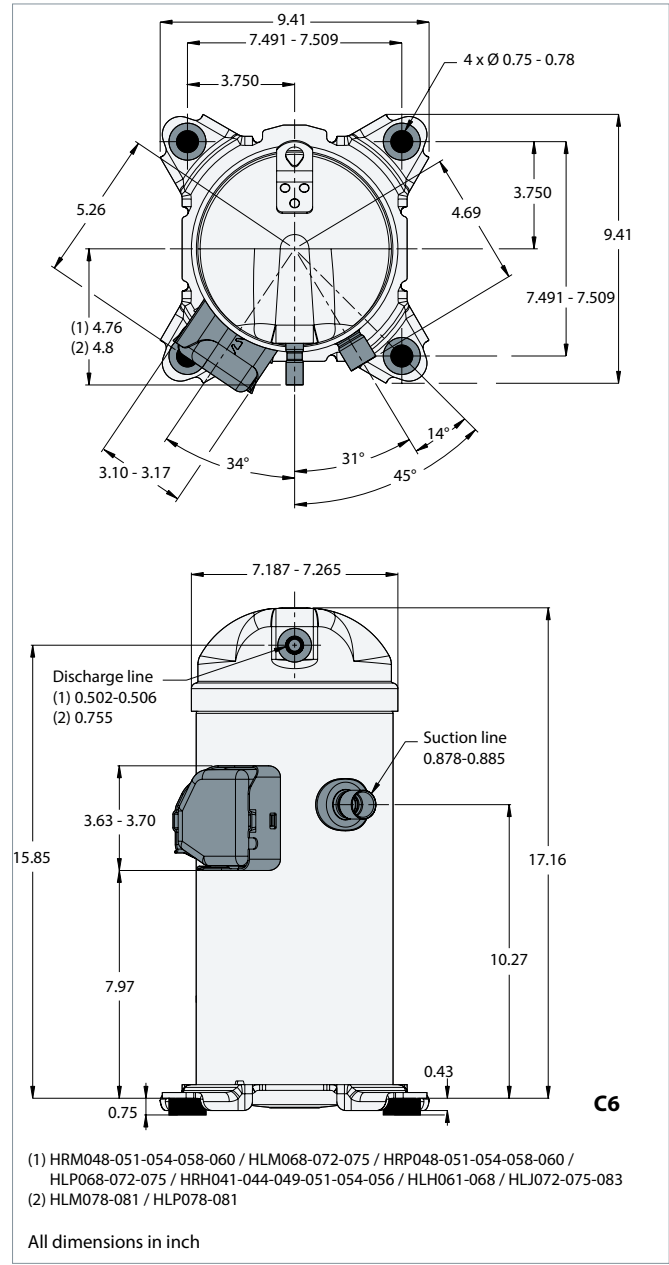
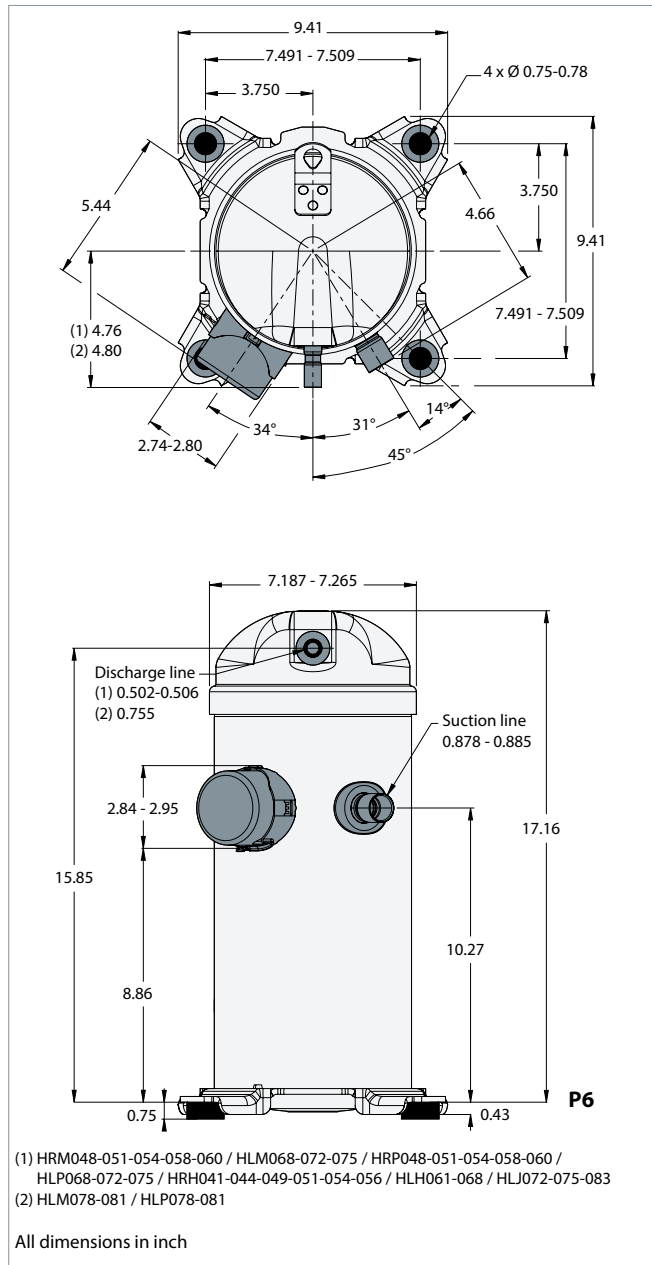

Terminal boxes

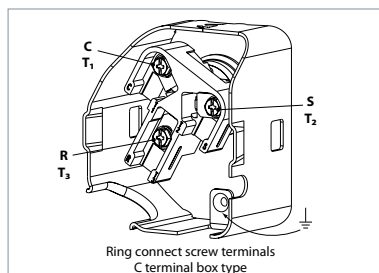
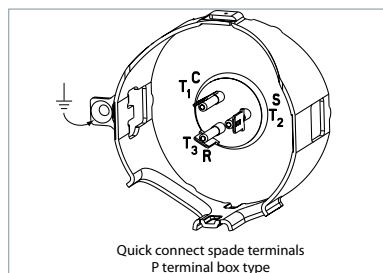

Mounting grommet

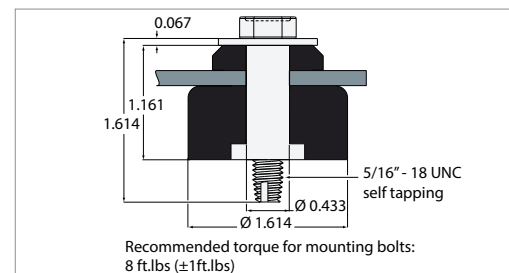

Refer to page 43 for overview of shipped mounting accessories

HCM/HCP 094-109-120

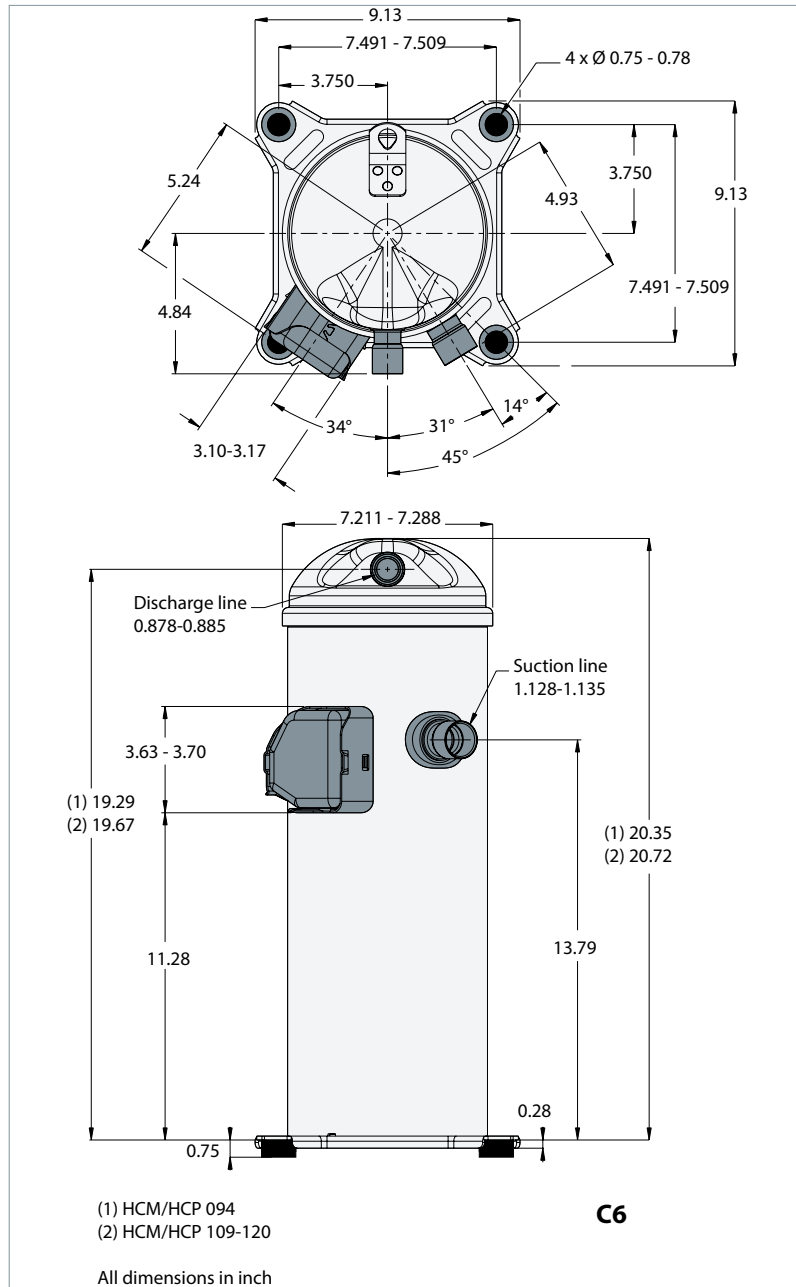

Terminal box

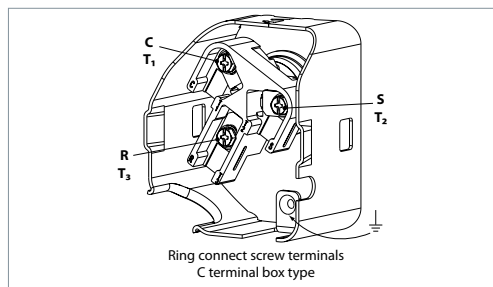

Mounting grommet

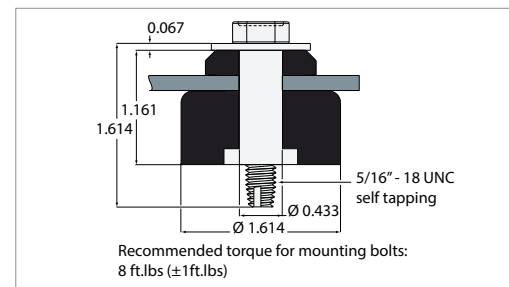

Refer to page 43 for overview of shipped mounting accessories

HCJ090-105-120

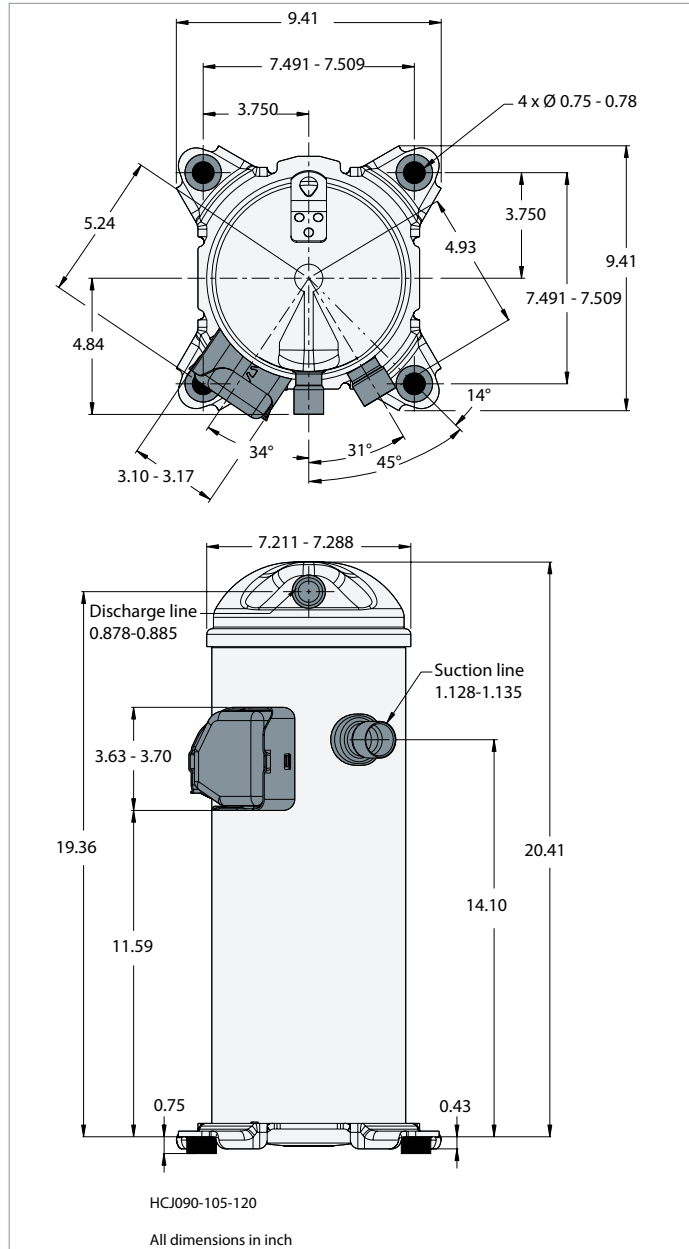

Terminal boxes

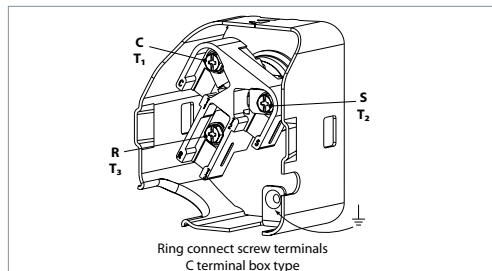

Mounting grommet

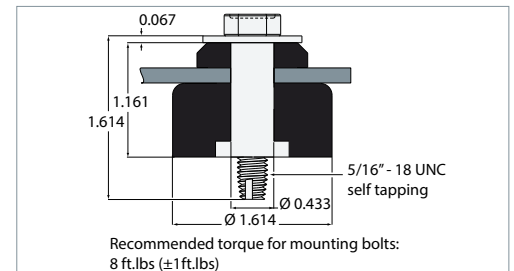

Refer to page 43 for overview of shipped mounting accessories

HCJ091-106-121

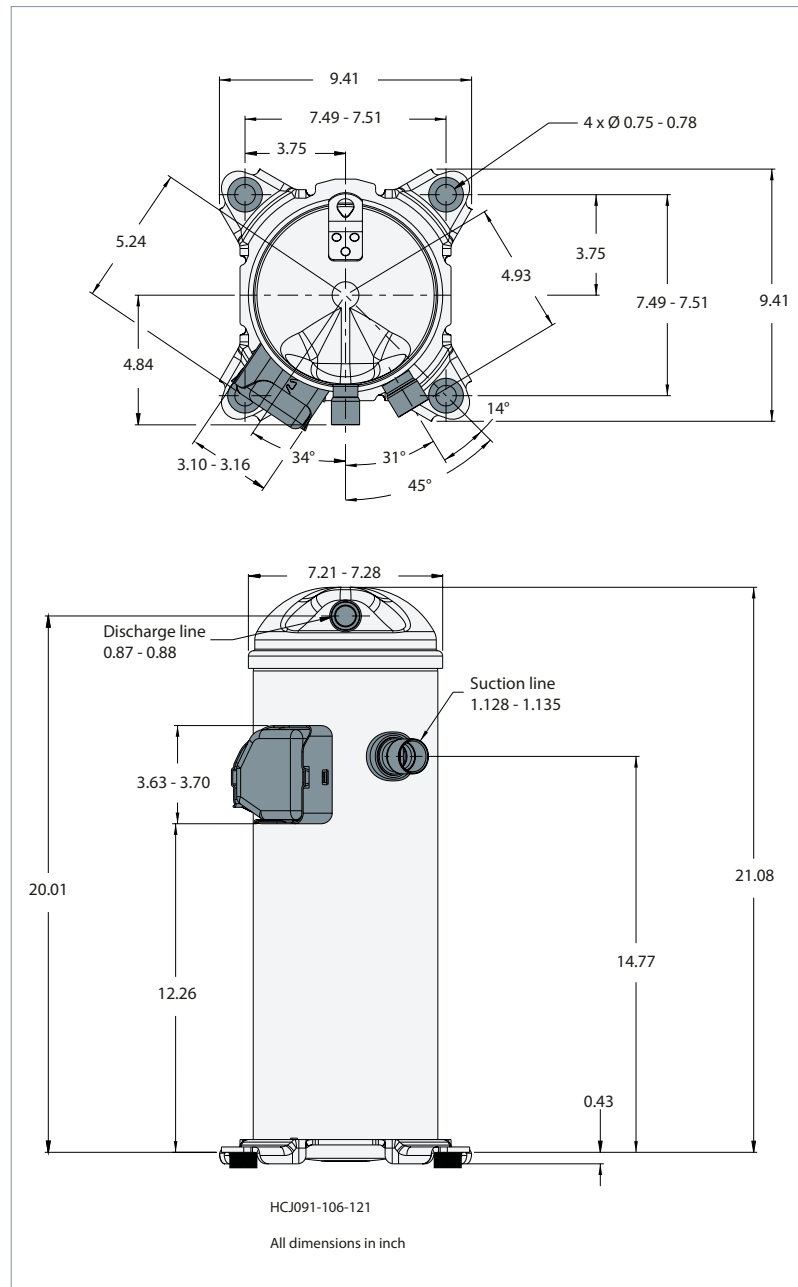

Terminal box

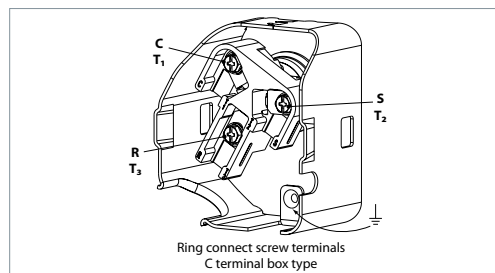

Mounting grommet

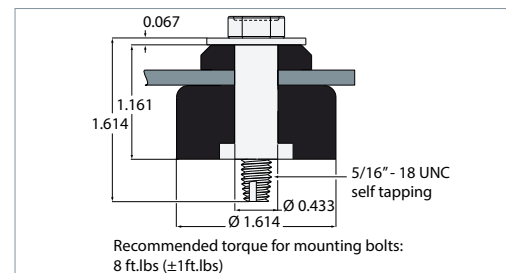

Refer to page 43 for overview of shipped mounting accessories

**HLH061-HLJ072-
HLJ083**

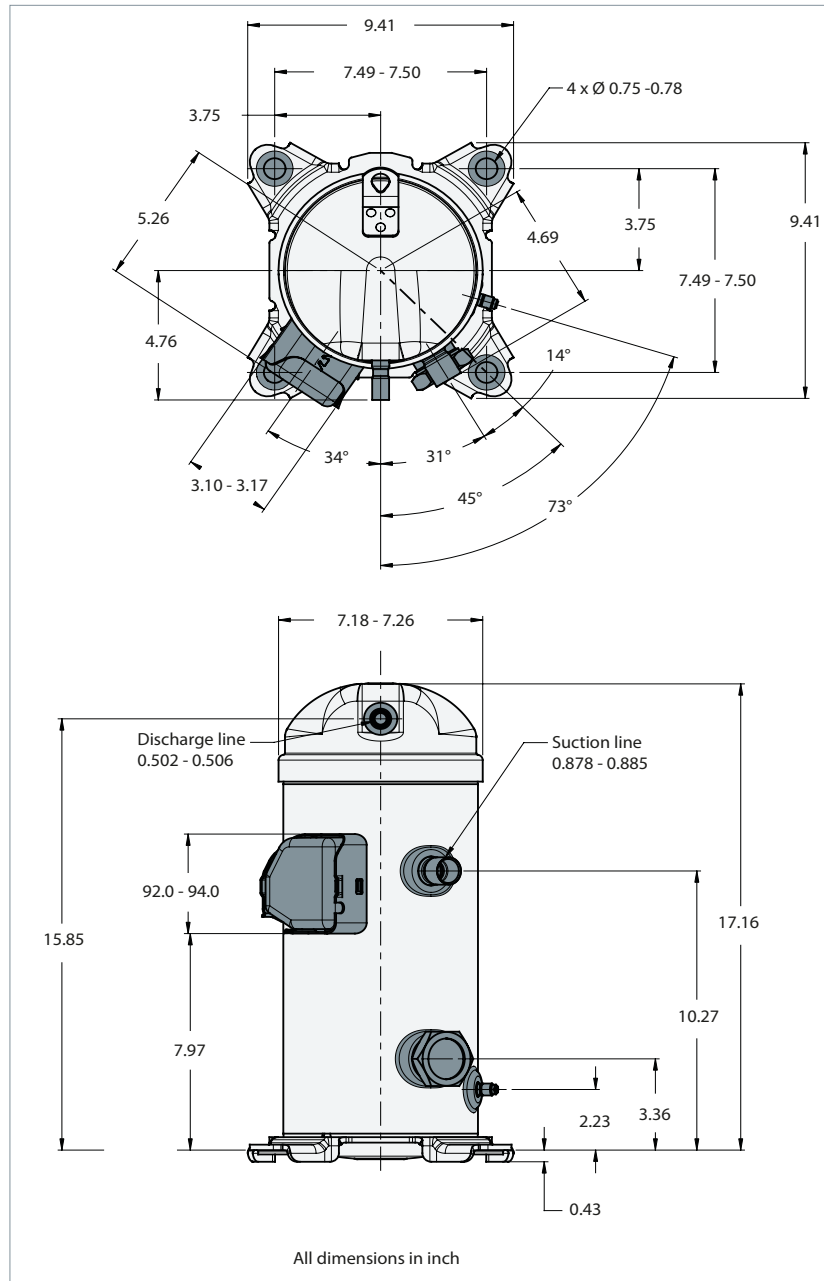

Terminal box

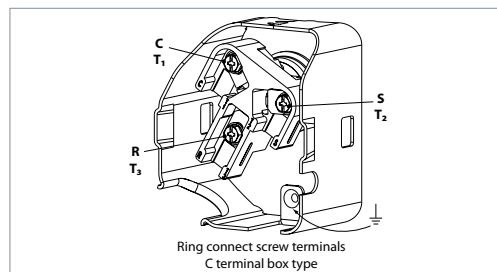

Mounting grommet

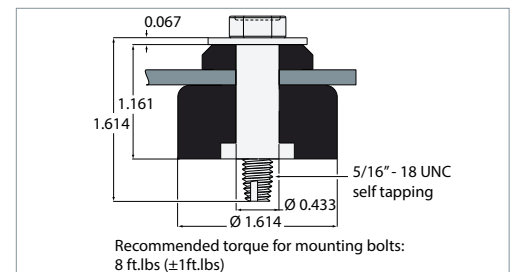

Refer to page 43 for overview of shipped mounting accessories

Version T compressors are built with a threaded oil equalization port to be used with our variable speed compressors range VZH.

Motor voltage Scroll compressors are available in 6 different motor voltages.

	Motor voltage code 1	Motor voltage code 2	Motor voltage code 4	Motor voltage code 5	Motor voltage code 7	Motor voltage code 9
Nominal voltage 50 Hz	-	200-220V-3-50 Hz	380-415V-3-50 Hz	220-240V-1-50 Hz	500V-3-50 Hz	-
Voltage range 50 Hz	-	180 - 242	342 - 457	198 - 264	450 - 550	-
Nominal voltage 60 Hz	208-230V-1-60 Hz	208-230V-3-60 Hz	460V-3-60 Hz	-	575V-3-60 Hz	380V-3-60 Hz
Voltage range 60 Hz	187 - 253	187 - 253	414 - 506	-	517 - 632	342 - 418

Prior to energizing, verify that leads and terminal connectors are in proper working condition.

Warning: For safety reasons, make voltage measurements at the unit contactor, not at compressor terminals. Always keep the terminal cover in place when the compressor is energized.

Wiring connections

Danfoss scroll compressors will only compress gas while rotating counter-clockwise (when viewed from the compressor top). Since single-phase motors will start and run in only one direction, reverse rotation is not a major consideration. Three-phase motors, however, will start and run in either direction, depending on the phase angles of the supplied power. Care must be taken during installation to ensure that the compressor

operates in the correct direction (see “Phase sequence and reverse rotation protection”).

The drawings below show electrical terminal labelling and should be used as a reference when wiring the compressor. For three phase applications, the terminals are labelled T1, T2, and T3. For single-phase applications the terminals are labelled C (common), S (start), and R (run).

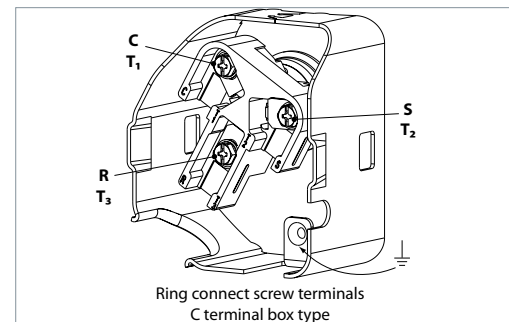
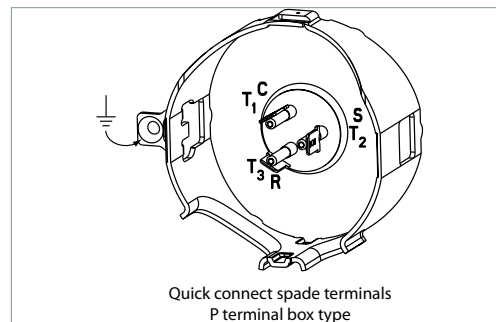

Terminal cover mounting

The terminal cover and gasket should be installed prior to operation of the compressor. The terminal cover has two outside tabs, 180 degrees apart, that engage the terminal fence. When installing

the cover, check that it is not pinching the lead wires. Both the inside of the terminal cover and the gasket have labels for the terminal pins: C (common), R (run), and S (start).

Terminal cover removal

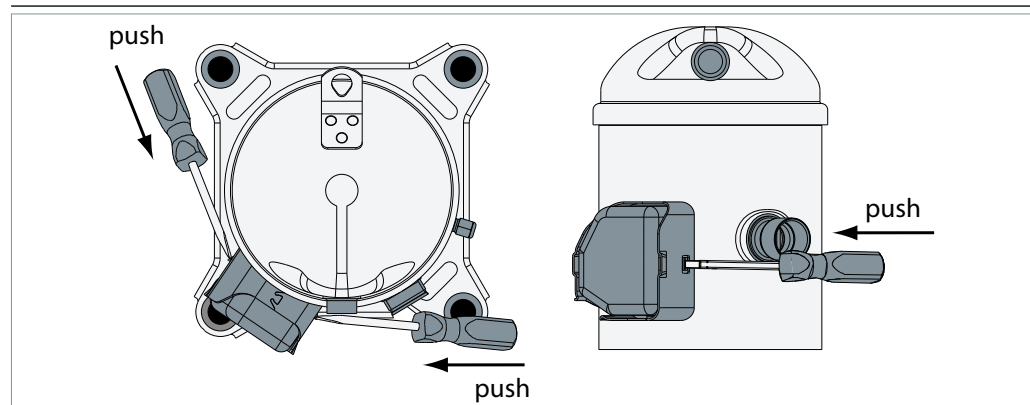

Application Guidelines

Electrical data, connections and wiring

IP rating

The compressor terminal box IP rating according to CEI 529 is **IP22** for all models. IP ratings is only valid when correctly sized cable glands of the IP rating is applied.

- First numeral, level of protection against contact and foreign objects
2 protection against object size over 1/2 inch (fingers of similar)
- Second numeral, level of protection against water
2 protection against dripping water when tilted up to 15°

LRA (Locked Rotor Amp)

LRA is the higher average current as measured on a mechanically blocked compressor tested under nominal voltage. LRA is printed on the nameplate.

The LRA value can be used as a rough estimation for the starting current. However in most cases, the real starting current will be lower. Many countries have defined limits for the starting current in domestic use. A soft starter can be applied to reduce starting current.

MCC (Maximum Continuous Current)

The MCC is the current at which the internal motor protection trips under maximum load and low voltage conditions.

This MCC value is the maximum at which the compressor can be operated in transient conditions and out of the application envelope. Above this value the overload will switch off to protect the motor.

Winding resistance

Winding resistance is the resistance between indicated terminal pins at 77°F (resistance value ± 7%).

Winding resistance is generally low and it requires adapted tools for precise measurement. Use a digital ohm-meter, a '4 wires' method and measure under stabilised ambient temperature. Winding resistance varies strongly with winding temperature ; If the compressor is stabilised at a different value than 77°F, the measured resistance must be corrected with following formula:

$$R_{t_{amb}} = R_{77^{\circ}F} \frac{a + t_{amb}}{a + t_{77^{\circ}F}}$$

$t_{77^{\circ}F}$: reference temperature = 77°F

t_{amb} : temperature during measurement (°F)

$R_{77^{\circ}F}$: winding resistance at 77°F

R_{amb} : winding resistance at t_{amb}

coefficient $a = 390$

Electrical connections

Danfoss scroll compressors are designed to operate without any assistance if running within

the defined nominal voltage. PSC wiring is sufficient (see below).

PSC wiring

The start winding (C-S) of the motor remains in circuit through a permanent (run) capacitor.

This permanent (run) capacitor is connected between the start winding (C-S) and the run winding (C-R).

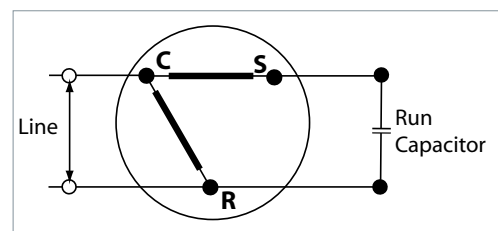

CSR wiring

If start assist is required, in case of operating below the nominal voltage, a CSR starting device is required.

During start-up, the start winding (C-S) is energised through an electromagnetic potential relay and a start capacitor.

A permanent (run) capacitor is wired between the start winding (C-S) and the run winding (C-R).

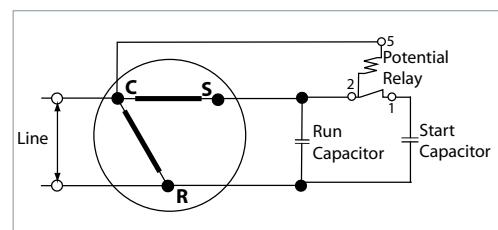

Nominal capacitor value and relays

	Models	PSC wiring Run capacitor	CSR wiring Start capacitor	Relay	
60 Hz, motor voltage code 1	R22	HRM032-034	45 µF	145-175 µF/370V	RVA 2AC3D
		HRM038	55 µF	88-108 µF/370V	RVA 2AB3D
		HRM040-042-045-047	60 µF	88-108 µF/370V	RVA 2AB3D
		HRM048	60 µF	161-193 µF/370V	RVA 2AB3D
		HRM051-054	70 µF	161-193 µF/370V	RVA 2AB3D
		HRM058T1-060T1	55 µF	88-108 µF/370V	RVA 4AG3D
		HRM058U1-060U1, HLM068-072-075-081	80 µF	189-227 µF/370V	RVA 2AB3D
	R407C	HRP051	70 µF	161-193 µF/370V	RVA 2AB3D
		HLP068-072-075-081	80 µF	189-227 µF/370V	RVA 2AB3D
	R410A	HRH031	45 µF	145-175 µF/370V	RVA 2AC3D
		HRH032-034	50 µF	88-108 µF/370V	RVA 2AB3D
		HRH036	55 µF	88-108 µF/370V	RVA 2B3D
		HRH038-039-040	60 µF	88-108 µF/370V	RVA 2AB3D
		HRH041-044-048-049-050-051	70 µF	161-193 µF/370V	RVA 2AB3D
HRH054-056, HLH068, HLJ072-083		80 µF	189-227 µF/370V	RVA 2AB3D	
HRM032-034-038-040-042		70 µF	145-175 µF/440V	RVA 2B3D	
50 Hz, motor voltage code 5	R22	HRM045-047	60 µF	145-175 µF/440V	RVA 2B3D
		HRM051	50 µF	161-193 µF/440V	RVA 3E3D
		HRM054	55 µF	161-193 µF/440V	RVA 3E3D
		HRM058-060	55 µF	88-108 µF/440V	RVA 4G3D
		HLM068-072-075-081	55 µF	88-108 µF/440V	RVA 4G3D
		HRP034-038-040-042	70 µF	145-175 µF/440V	RVA 2B3D
		HRP045-047	60 µF	145-175 µF/440V	RVA 2B3D
	R407C	HRP051	50 µF	161-193 µF/440V	RVA 3E3D
		HRP054	55 µF	161-193 µF/440V	RVA 3E3D
		HRP058-060	55 µF	88-108 µF/440V	RVA 4G3D
		HLP068-072-075-081	55 µF	88-108 µF/440V	RVA 4G3D
	R410A	HRH031-032-034-036	70 µF	145-175 µF/440V	RVA 2B3D
		HRH038-040	60 µF	145-175 µF/440V	RVA 2B3D
		HRH050-051-054-056-061	55 µF	88-108 µF/440V	RVA 4G3D
	HLH068, HLJ072-083	55 µF	88-108 µF/440V	RVA 4G3D	

Internal motor protection

Danfoss scroll compressors are equipped with an internal line break protector mounted on the motor windings. The protector is an automatic reset device, containing a snap action bimetal switch.

Internal protectors respond to over-current and overheating. They are designed to interrupt

motor current under a variety of fault conditions, such as failure to start, running overload, and fan failure.

If the internal overload protector trips out, it must cool down to about 140°F to reset. Depending on ambient temperature, this may take up to several hours.

Phase sequence and reverse rotation protection

The compressor will only operate properly in a single direction. Use a phase meter to establish the phase orders and connect line phases L1, L2 and L3 to terminals T1, T2 and T3, respectively. For three-phase compressors, the motor will run equally well in both directions. Reverse rotation results in excessive noise; no pressure differential between suction and discharge; and suction line warming rather than immediate cooling. A service technician should be present at initial start-up to verify that supply power is properly phased and that compressor and auxiliaries are rotating in the correct direction.

DanfossH-series through Hxx075 scroll compressors are designed to operate for a maximum of 150 hours in reverse, but as a reverse rotation situation can go unnoticed for longer periods, phase monitors are recommended.

For compressors Hxx078 and larger, phase monitors are required. The selected phase monitor should lock out the compressor from operation in reverse.

At brief power interruptions, reverse rotation can occur with single phase compressors. In this case the internal protector will stop the compressor. It will have to cool down and will restart safely afterwards.

Voltage imbalance

For three-phase applications the voltage measured at the compressor terminals for each

phase should be within ± 2% of the average for all phases.

Application Guidelines

Approvals and certifications

Approvals and certificates

Danfoss H-series compressors comply with the following approvals and certificates. Certificates are listed on the product datasheets: <http://www.danfoss.com/odsg>

CE 0062 or CE 0038 (European Directive)		All models
UL (Underwriters Laboratories)		All 60 Hz models
Other approvals / certificates		Contact Danfoss

Pressure equipment directive 97/23/EC

Products	
Refrigerating fluids	Group 2
Category PED	I
Evaluation module	no scope

Low voltage directive 73/23/EC, 93/68/EC

Products	
Manufacturer's declaration of incorporation ref. EC Machines Directives 98/392/CE	Contact Danfoss

Internal free volume

Products	Internal free volume at LP side without oil (gallon)	Internal free volume at HP side without oil (gallon)
HRM/P032-034-038-040-042 HRH029-031-032-034-036-038	0.77	0.13
HRM/P045-047 HRH040	0.84	0.18
HRM/P048-051-054-058-060, HLM/P068-072-075-081 HRH044-049-051-054-056, HLH/J061-068-072-075-083	0.90	0.19
HCM/P094-109-120 HCJ090-105-120	1.56	0.13
HCJ091-106-121	1.51	0.13

Application Guidelines

Operating conditions

The Danfoss scroll compressor H-Series application range is influenced by several parameters which need to be monitored for a safe and reliable operation. These parameters and the main recommendations for good practice and safety devices are explained hereunder.

- **Refrigerant and lubricants**
- **Motor supply**
- **Compressor ambient temperature**
- **Application envelope** (evaporating temperature, condensing temperature, return gas temperature)

Refrigerant and lubricants

General information

When choosing a refrigerant, different aspects must be taken into consideration:

- Legislation (now and in the future)
- Safety
- Application envelope in relation to expected running conditions
- Compressor capacity and efficiency

- Compressor manufacturer recommendations & guidelines
- Additional points could influence the final choice:
- Environmental considerations
 - Standardisation of refrigerants and lubricants
 - Refrigerant cost
 - Refrigerant availability

PVE

Polyvinyl ether (PVE) is an innovative refrigeration lubricant for HFC refrigerant systems. PVE is as hygroscopic as existing polyolester lubricants (POE), but PVE doesn't chemically react with water; no acids are formed and compressor evacuation is easier.

The compressor technology applied in Danfoss H-series scroll compressors in combination with PVE lubricant provides the best possible result in terms of reliability and compressor lifetime. The PVE lubricant is compatible with R22 which makes the Danfoss H-series scroll compressors a very versatile multi-refrigerant solution.

Alkylbenzene oil

Alkylbenzene oil can be applied in systems using HCFC refrigerants (R22). Compared to a mineral oil it provides distinct advantages: excellent miscibility, excellent thermal stability, compatibility with mineral oils and constant quality.

Danfoss Scroll H_M series compressors are charged with Alkylbenzene oil and herewith offer an economically interesting alternative to the Danfoss H series in regions where R22 is still the predominant refrigerant. Note however that Danfoss H-series scroll compressors can not be used with HFC refrigerants.

Oil type

Danfoss scroll compressors are charged with oil at the factory with the oils indicated, in the following table.

Compressor range	Oil type
HRM / HLM / HCM	Alkylbenzene
HRP / HLP / HCP	PVE
HRH / HLH	PVE
HLJ / HCJ	PVE

Effective week 31 of 2009, the HRP/HLP/HCP & HRH/HLH series of compressors were changed from POE oil to PVE oil. Compressors produced prior to this week still had POE, and may be in stock in the warehouses until supply is exhausted. This change was made to standardize to the better oil for reliability. Replacement PVE 320HV is available for topping up or replacing oil in the field (see accessory section). As it is fully miscible with POE, Danfoss recommends the 320HV regardless of original oil charge in the compressor.

Residual moisture

Prior to shipment from the factory, every compressor is dehydrated, evacuated, and charged with dry nitrogen. Maximum residual

moisture levels are 0.0082 oz. for models capacities up to HRM/HRP047 and HRH040 and 0.0120 oz. for larger compressors.

Application Guidelines

Operating conditions

Run-in process

Our H product ranges feature a compliance technology which allows

- an exceptional slugging capability (radial compliance)
- a very low starting torque (axial compliance)

When a compressor with compliance technology is new, the performance is not immediately at peak. A run-in period is needed to polish all surfaces as well as to reduce friction and leakage. The run-in period eliminates extra power input

Motor supply

Danfoss scroll compressors H-series can be operated at nominal voltages as indicated on "Motor voltage" section. Under-voltage and over-voltage operation is allowed within the indicated

voltage ranges. In case of risk of under-voltage operation, special attention must be paid to current draw and start assist for single-phase compressors may be required.

Compressor ambient temperature

Danfoss scroll compressors H-series can be applied from -30°F to 120°F ambient temperature. The compressors are designed as 100 % suction

gas cooled without need for additional fan cooling. Ambient temperature has very little effect on the compressor performance.

High ambient temperature

In case of enclosed fitting and high ambient temperature it's recommend to check the temperature of power wires and conformity to their insulation specification.

In case of safe tripping by the internal compressor overload protection the compressor must cool down to about 140°F before the overload will reset. A high ambient temperature can strongly delay this cool-down process.

Low ambient temperature

Although the compressor itself can withstand low ambient temperature, the system may require specific design features to ensure safe and reliable

operation. See section 'Specific application recommendations'.

Application envelope

The operating envelopes for Danfoss scroll compressors are given in the figures below, where the condensing and evaporating temperatures represent the range for steady-state operation. Under transient conditions, such as start-up and defrost for heat pump applications, the compressor may operate outside this envelope for short periods.

The figures below show the operating envelopes for HR/HL/HC compressors with refrigerants R22, R407C and R410A with model variation related to

T or U design optimization. The operating limits serve to define the envelope within which reliable operations of the compressor are guaranteed:

- Maximum discharge gas temperature: +275°F
- A suction superheat below 9 °F is not recommended due to the risk of liquid flood back
- Maximum superheat of 54°F
- Minimum and maximum evaporating and condensing temperatures as per the operating envelopes.

R22, R407C Model variation T

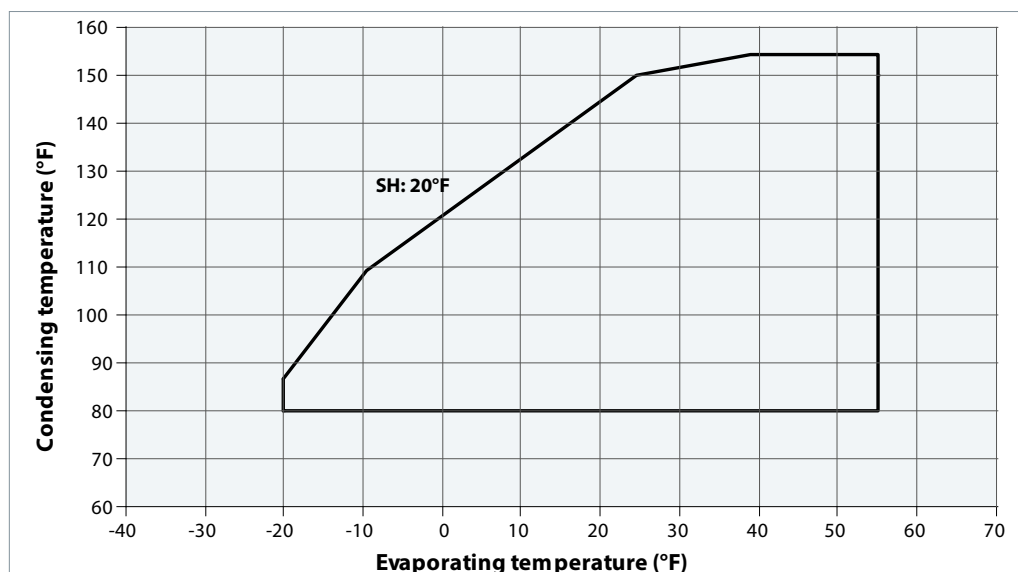

**R410A
Model variation T**

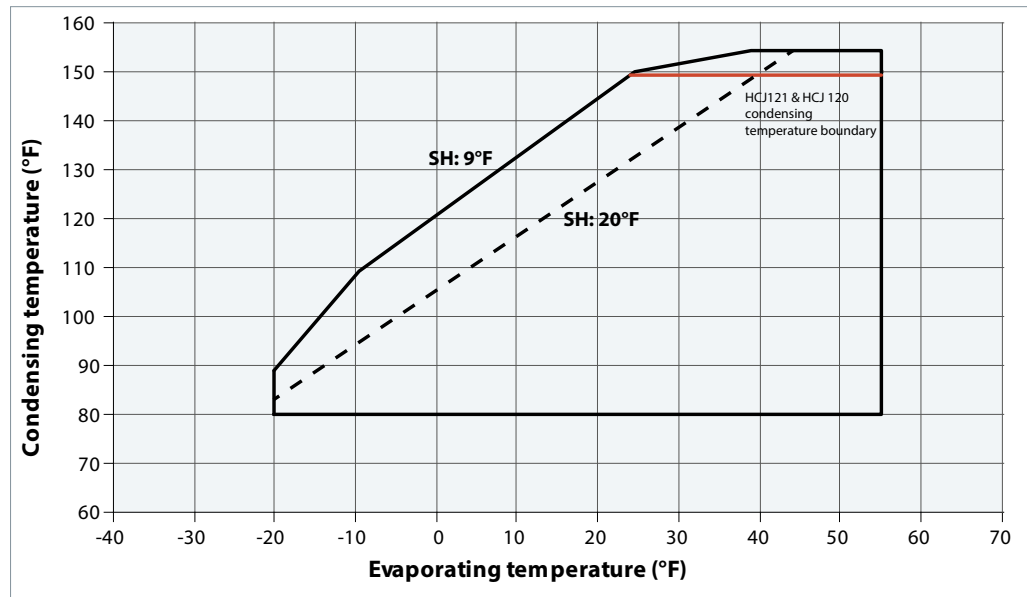

**R22, R410A
Model variation U**

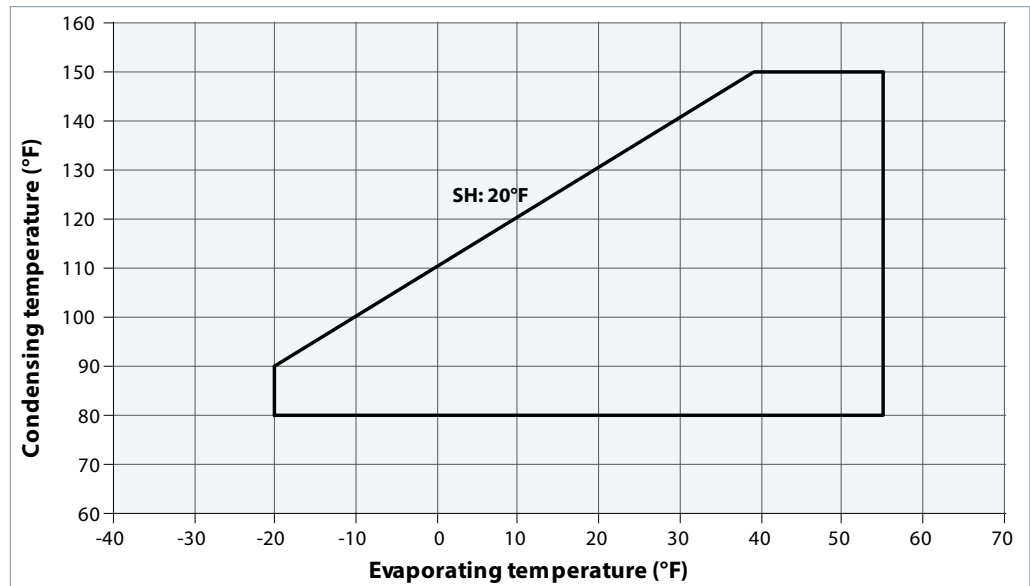

**Maximum discharge
gas temperature**

The discharge temperature depends mainly on the combination of evaporating temperature, condensing temperature and suction gas superheat. Discharge gas temperature should be controlled with an isolated thermocouple or

thermostat attached to the discharge line 6 in. from the compressor shell. Maximum discharge gas temperature must not exceed 275°F when the compressor is running within the approved operating envelope.

Discharge gas temperature protection (DGT)

DGT protection is required if the high and low pressure switch settings do not protect the compressor against operations beyond its specific application envelope. Please refer to the examples below, which illustrate where DGT protection is required (n°1) and where it is not (n°2).

The compressor must not be allowed to cycle on the discharge gas thermostat. Continuous operations beyond the compressor's operating range will cause serious damage to the compressor!

A DGT accessory is available from Danfoss: refer to page 43.

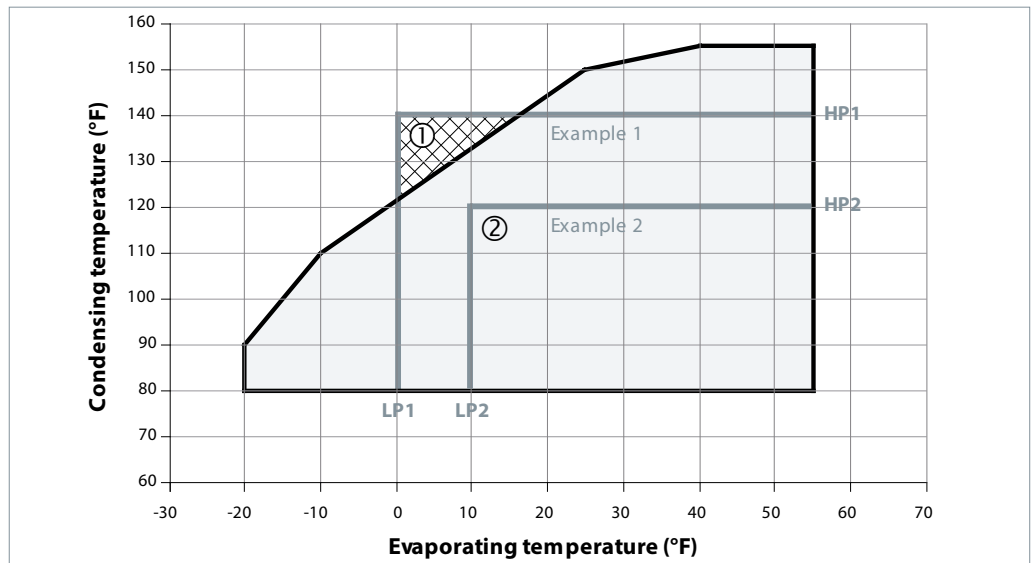

Example 1 (R410A, SH = 20°F)
 LP switch setting: LP1 = 60 psig (0°C)
 HP switch setting: HP1 = 550 psig (140°F)
 ① The LP and HP switches don't protect sufficiently from operation outside the envelope. A DGT protection is required to avoid operation in the hatched area.

Example 2 (R410A, SH = 20°F)
 LP switch setting: LP2 = 75 psig (10°F)
 HP switch setting: HP2 = 430 psig (120°F)
 ② The LP and HP switches protect from operation outside the envelope. No DGT protection required.

Application Guidelines

Operating conditions

The discharge gas temperature must not exceed 275°F.

The discharge gas thermostat accessory kit includes all components required for installation, as shown below. The thermostat must be attached to the discharge line within 6 in. from the compressor discharge port.

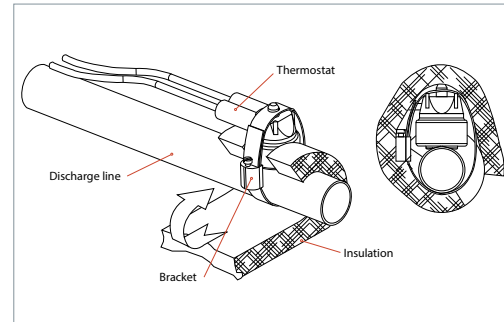

Discharge thermostat kit code number: 7750009.

High and low pressure protection

		R22	R407C	R410A
Working pressure range high side	psig	158 - 402 ③	152 - 422 ③	229 - 645 ③
Working pressure range low side	psig	20 - 100 ③	16 - 93 ③	28 - 157 ③
Maximum high pressure safety switch setting	psig	421	435	653
Minimum low pressure safety switch setting ①	psig	7	7	22
Minimum low pressure pump-down switch setting ②	psig	19	15	33
Maximum pressure test	psig	435	435	435

- ① LP safety switch shall never be bypassed.
- ② Recommended pump-down switch settings: 22 psi (R22, R407C) and 36 psi (R410A) below nominal evaporating pressure.
- ③ Depends on the models, check on the nameplate

High pressure

A high-pressure (HP) safety switch is recommended to shut down the compressor should the discharge pressure exceed the values shown in the table below. The high-pressure switch can be set to lower values depending on the application and ambient conditions. The HP switch must either be placed in a lockout circuit or consist of a manual reset device to prevent cycling around the high-pressure limit. If a discharge valve is used, the HP switch must be connected to the service valve gauge port, which must not be isolated.

Note: because power consumption of scroll compressors is almost directly proportional to discharge pressure, the high-pressure control can be used to indirectly limit the maximum current draw. A high-pressure control used in this manner however can never replace an external overload protector.

Danfoss HCM/HCP/H CJ scroll compressors are not equipped with an internal pressure relief valve; therefore a high pressure switch is required, set no higher than the limits given in the table above.

Low pressure

A low pressure (LP) safety switch is recommended. Deep vacuum operations of a scroll compressor can cause internal electrical arcing and scroll instability. Danfoss scroll compressors exhibit high volumetric efficiency and may draw very low vacuum levels, which could induce such a problem. The minimum low-pressure safety switch (loss of charge safety switch) setting is

given in the following table. For systems without pump-down, the LP safety switch must either be a manual lockout device or an automatic switch wired into an electrical lockout circuit. The LP switch tolerance must not allow for vacuum operations of the compressor. LP switch settings for pump-down cycles with automatic reset are also listed in the table above.

On/off cycling (cycle rate limit)

Danfoss recommends a restart delay timer to limit compressor cycling. The timer prevents reverse compressor rotation, which may occur during brief power interruptions.

cooling after start-up along with proper oil return. Note that the oil return may vary since it depends upon system design.

The system must be designed in a way that guarantees a minimum compressor running time of 2 minutes so as to provide for sufficient motor

There must be no more than 12 starts per hour, a number higher than 12 reduces the service life of the motor-compressor unit. A three-minute (180-sec) time out is recommended.

General

Successful application of scroll compressors is dependent on careful selection of the compressor for the application. If the compressor is not correct

for the system, it will operate beyond the limits given in this manual. Poor performance, reduced reliability, or both may result.

Essential piping design considerations

Proper piping practices should be employed to ensure adequate oil return, even under minimum load conditions with special consideration given to the size and slope of the tubing coming from the evaporator. Tubing returns from the evaporator should be designed so as not to trap oil and to prevent oil and refrigerant migration back to the compressor during off-cycles.

If the evaporator lies above the compressor, as is often the case in split or remote condenser systems, the addition of a pump-down cycle is strongly recommended. If a pump-down cycle were to be omitted, the suction line must have a loop at the evaporator outlet to prevent refrigerant from draining into the compressor during off-cycles.

If the evaporator were situated below the compressor, the suction riser must be trapped so as to prevent liquid refrigerant from collecting at the thermal bulb location (see fig. 1).

When the condenser is mounted at a higher position than the compressor, a suitably sized «U»-shaped trap close to the compressor is

necessary to prevent oil leaving the compressor from draining back to the discharge side of the compressor during off cycle. The upper loop also helps avoid condensed liquid refrigerant from draining back to the compressor when stopped (see fig. 2). The maximum elevation difference between the indoor and outdoor section cannot exceed 26 feet. System manufacturers should specify precautions for any applications that exceed these limits to ensure compressor reliability.

Piping should be designed with adequate three-dimensional flexibility. It should not be in contact with the surrounding structure, unless a proper tubing mount has been installed. This protection proves necessary to avoid excess vibration, which can ultimately result in connection or tube failure due to fatigue or wear from abrasion. Aside from tubing and connection damage, excess vibration may be transmitted to the surrounding structure and generate an unacceptable noise level within that structure as well (for more information on noise and vibration, see the section on: "Sound and vibration management" p.28).

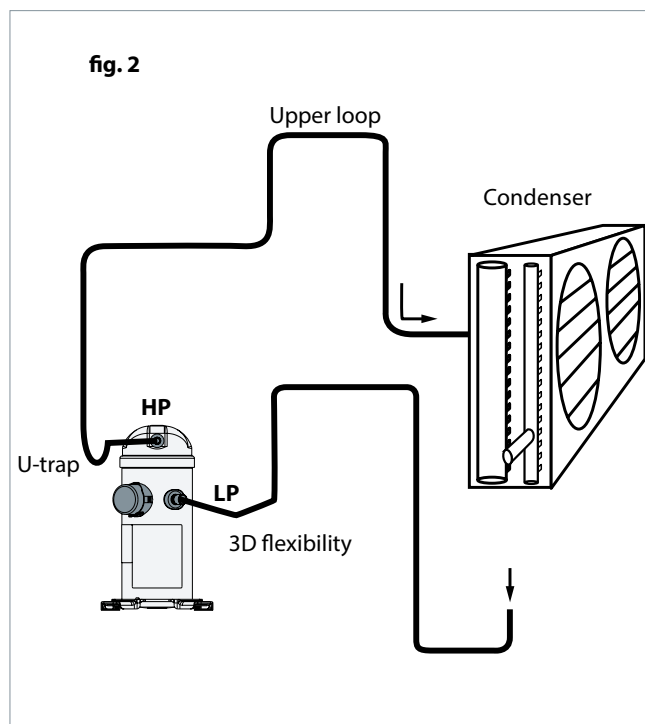
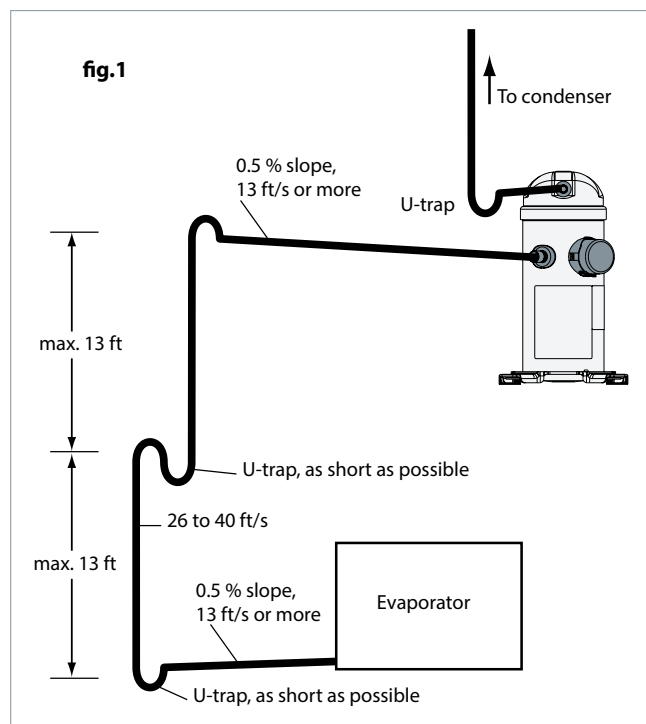

Refrigerant charge limit

Scroll compressors can tolerate liquid refrigerant up to a certain extend without major problems. However, excessive liquid refrigerant in the compressor is always unfavourable for service life. Besides, the installation cooling capacity may be reduced because of the evaporation taking place in the compressor and/or the suction line instead of the evaporator. System design must be such that the amount of liquid refrigerant in the compressor is limited. In this respect, follow the guidelines given in the section: "Essential piping design recommendations" in priority.

Use the tables below to quickly evaluate the required compressor protection in relation with the system charge and the application. More detailed information can be found in the paragraphs hereafter. Please contact Danfoss for any deviation from these guidelines.

Notes: for reversible heat pump systems and other specific applications, please refer to section "Specific application recommendations".

Compressor models	Refrigerant charge limit (lbs)
HRM032-034-038-040-042-045-047 HRP034-038-040-042-045-047	8
HRH029-031-032-034-036-038-039-040-047-048-050 HRM048-051-054-058-060 / HLM068-072-075-078-081 HRP048-051-054-058-060 / HLP068-072-075-078-081 HRH041-044-049-051-054-056 / HLH061-068 - HLJ072-075-083	12
HCM094-109-120 HCP094-109-120 HCJ090-091-105-106-120-121	16

Depending on test results, crankcase heaters, Liquid Line Solenoid Valve, pump down or suction accumulator must be applied see below.

	BELOW charge limit	ABOVE charge limit
Packaged units	<input checked="" type="checkbox"/> No test or additional safeties required	REQ Off cycle migration test REQ Liquid flood back test
System with remote heat exchanger	REC Off cycle migration test	REQ Off cycle migration test REQ Liquid flood back test
	REC Recommended REQ Required <input checked="" type="checkbox"/> No test or additional safeties required	

Note: for special conditions such as low ambient temperature, low load operation or brazed plate heat exchangers please refer to corresponding sections

Split unit heating mode

Repeat the test, but with the system in heating mode and the outdoor temperature at 0°F (-17.8°C) dry bulb. If the sump superheat is not in

the “ACCEPTABLE ZONE” shown in the Flood back Requirement graph on the next page, a suction accumulator is required.

Heat pumps

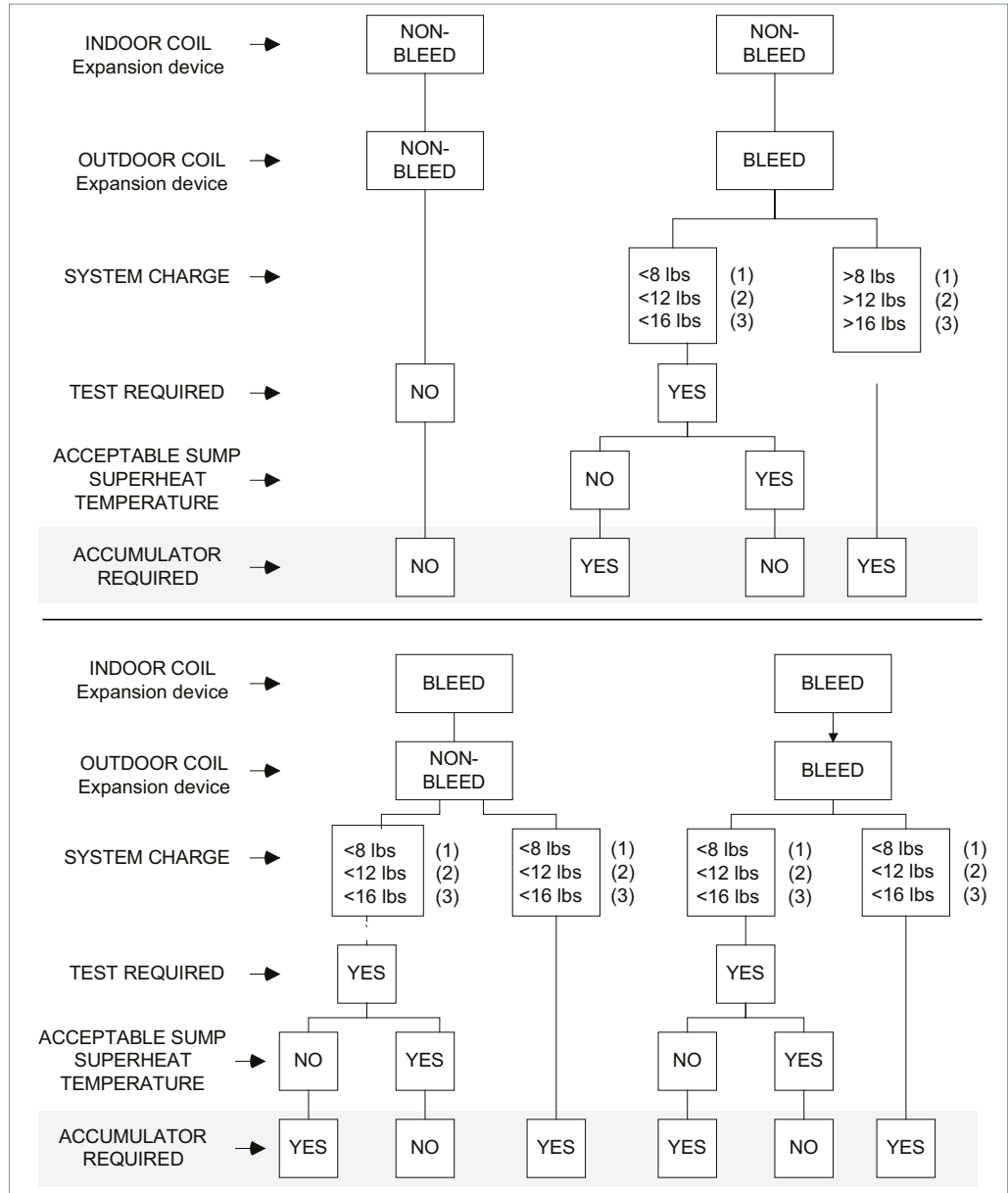

- (1) HRM032-034-038-040-042-045-047 - HRP034-038-040-042-045-047 - HRH029-031-032-034-036-038-039-040-047-048-050
- (2) HRM048-051-054-058-060 / HLM068-072-075-078-081 - HRP048-051-054-058-060 / HLP068-072-075-078-081 - HRH041-044-049-051-054-056 / HLH061-068 - HLJ072-075-083
- (3) HCM094-109-120 - HCP094-109-120 - HCJ090-091-105-106-120-121

Application Guidelines **System design recommendations**

Air-conditioning

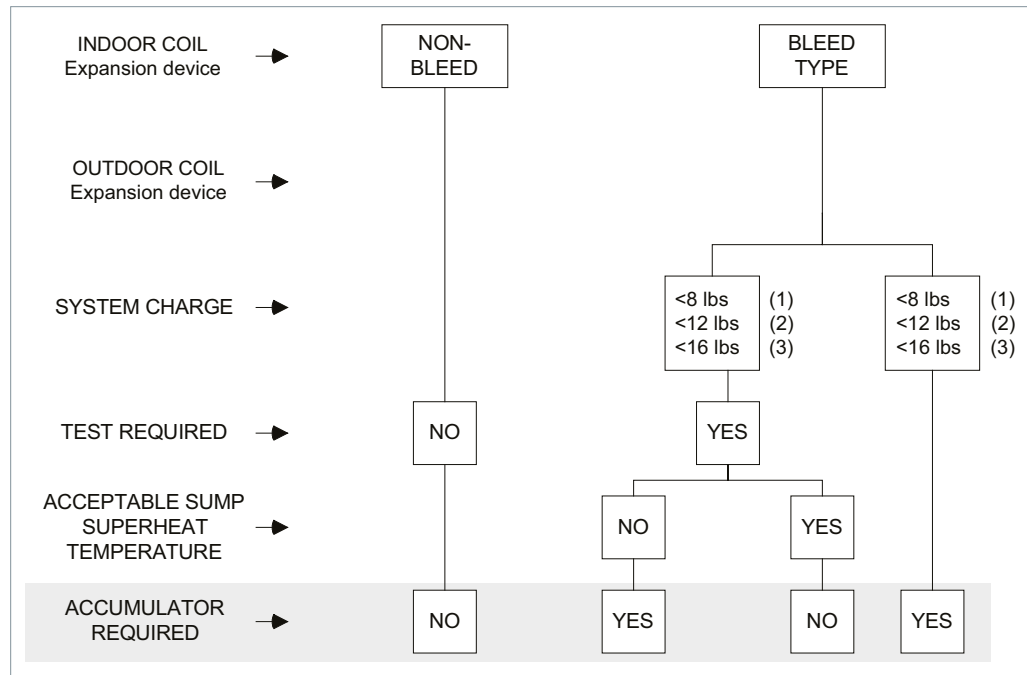

- (1) HRM032-034-038-040-042-045-047 - HRP034-038-040-042-045-047 - HRH029-031-032-034-036-038-039-040-047-048-050
- (2) HRM048-051-054-058-060 / HLM068-072-075-078-081 - HRP048-051-054-058-060 / HLP068-072-075-078-081 - HRH041-044-049-051-054-056 / HLH061-068 - HLJ072-075-083
- (3) HCM094-109-120 - HCP094-109-120 - HCJ090-091-105-106-120-121

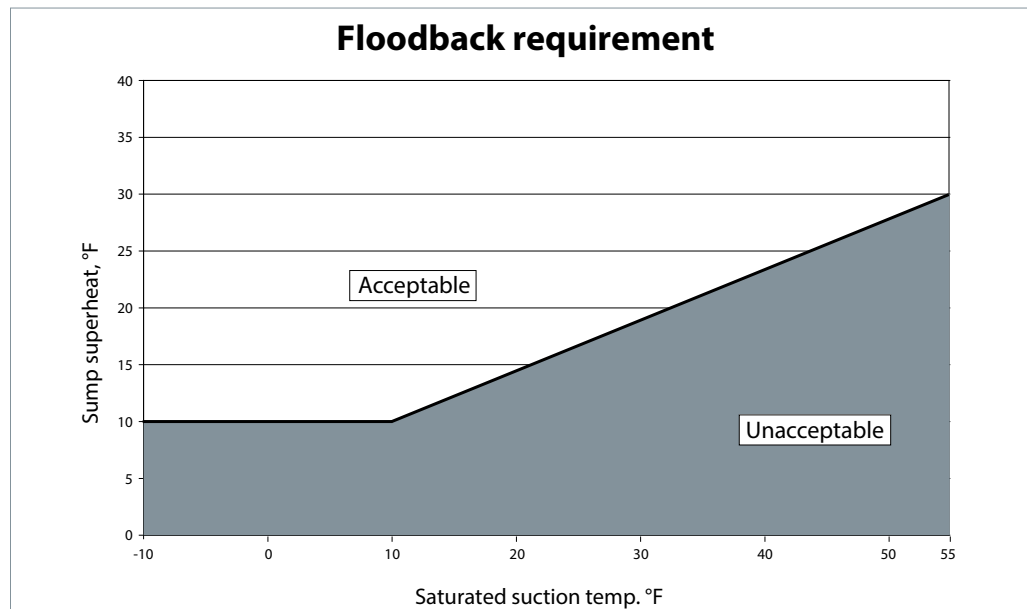

Crankcase heater

Crankcase heaters provide extra compressor protection, and should be considered for all applications. For HCM/HCP 094 - 109 - 120 and HCJ090-091-105-106-120-121, to prevent excessive refrigerant migration during off cycles, a crankcase heater is required. For initial installation of precharged systems and for any extended power interruptions, the crankcase heater should be energized for 24 hours prior to compressor startup.

Application Guidelines

System design recommendations

Reversible heat pump systems

Transients are likely to occur in reversible heat pump systems, i.e. a changeover cycle from cooling to heating, defrost or low-load short cycles. These transient modes of operation may lead to liquid refrigerant carryover (or flood back) or excessively wet refrigerant return conditions. As such, reversible cycle applications require specific precautions for ensuring a long compressor life and satisfactory operating characteristics. Regardless of the refrigerant charge in the system, specific tests for repetitive flood back

are required to confirm whether or not a suction accumulator needs to be installed. A crankcase heater and discharge gas thermostat are required for reversible heat pump applications.

These considerations cover the most important issues in the realm of common applications. Each application design however should be thoroughly tested to ensure acceptable operating characteristics.

Loss of charge protection

Danfoss HCM/HCP/H CJ scroll compressors do not include a thermal valve protection; therefore, all applications require loss of charge protection :

- For Air Conditioning, a low pressure switch in the low pressure side of the system is required.

- For Heat pump applications a discharge line thermostat set no higher than 275°F is required. The thermostat must be a manual lockout type device (or electrical lockout circuit) and be located within 5.90 in. of the compressor discharge connection. The discharge line thermostat must be insulated to insure proper sensing and operation.

Tandem

Danfoss scroll compressors in C8 version can be mounted in tandem assemblies.

Such manifolding applications require special design considerations that go beyond the scope of this document. Please contact Danfoss for further information.

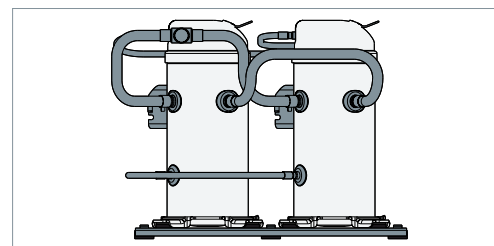

Oil level checking and top-up

In installations with good oil return and line runs up to 50 ft, no additional oil is required. If installation lines exceed 50 ft, additional oil may be needed. 1 or 2% of the total system refrigerant charge (in weight) can be used to roughly define the required oil top-up quantity.

Always use oil from new cans. Top-up the oil while the compressor is idle. Use any accessible connector on the compressor suction line and a suitable pump.

Minimum sump superheat

The minimum sump temperature is in the range from 10°F to 30°F above saturated suction

temperature.

High pressure ratio

Scroll compressors are machines with fixed volume ratio, and operate more efficiently near the design pressure ratio. In the extreme, do not exceed a 7.5:1 pressure ratio (absolute discharge pressure to absolute suction pressure) for

extended periods. The Danfoss scroll compressor is equipped with an internal pressure relief valve for protection against blocked condenser and fan failure conditions.

Phase sequence and reverse rotation protection

Use a phase meter to establish the phase orders and connect line phases L1, L2 and L3 to terminals T1, T2 and T3, respectively. The compressor will only operate properly in a single direction, and the motor is wound so that if the connections are correct, the rotation will also be correct. This is particularly important with three-phase compressors since the motor will run equally

well in both directions. Reverse rotation results in excessive noise; no pressure differential between suction and discharge; and suction line warming rather than immediate cooling. A service technician should be present at initial start-up to verify that supply power is properly phased and that compressor and blowers are rotating in the correct direction. Danfoss Scroll compressors

are designed to operate for a maximum of 150 cycles (hours) in reverse, but as a reverse rotation situation can go unnoticed for longer periods, phase monitors are recommended.

For compressors HLM078, HLP081, HLJ083 and larger, phase monitors are required for all applications. Danfoss recommends phase protection for residential compressors. The selected phase sensing device should lock out the compressor from operation in reverse.

Internal motor protection

Danfoss scroll compressors are equipped with internal line break protectors mounted on their motor windings. The protectors are automatic reset devices, each containing a snap action bimetal switch.

such as failure to start, running overload, and fan failure. In single-phase compressors, internal protectors guard against external miswiring, such as reversing electrical connections to the Run (R) and Start (S) terminals. In three-phase compressors the internal protectors provide protection during secondary single-phase conditions (loss of phase).

Internal protectors respond to over-current and to high temperature. They are designed to interrupt motor current under a variety of fault conditions,

Preventing liquid flood back

Danfoss recommends the use of a thermostatic expansion valve for all air conditioning and heat pump applications. A TXV has two key benefits: it provides modulating control of the system under varying load conditions, and it protects the compressors from flood back during adverse running conditions.

Excessive liquid refrigerant flood back during steady state operation is a major system design consideration for all types of compressors. Oil dilution that occurs with excessive flood back can have a significant adverse effect on bearing reliability. Suction accumulators may be required in some applications to prevent flood back.

Testing for excessive liquid flood back

When the use of fixed orifice devices is specified in the system design, and when a TXV is applied at the limit of its control range, the following tests

should be conducted to determine if a suction accumulator is needed.

Split unit cooling mode

Set up a system with the smallest rated indoor section for the tested outdoor section. Charge the system with 120% of the system nameplate charge using 25 ft. (7.62 m) of interconnecting tubing. Ensure that both indoor and outdoor sections have full airflow. Apply voltage to the compressor. Operate the system at 115°F (46.1°C) dry bulb outdoor and 67°F (19.4°C) dry bulb and

57°F (13.9°C) wet bulb indoor for a minimum of one hour. Unless the sump superheat is in the area designated "Acceptable Zone" in the chart "Floodback requirement", a suction accumulator is required. (Sump superheat is found by subtracting saturated suction temperature from compressor base temperature.)

Water utilising systems

Apart from residual moisture in the system after commissioning, water could also enter the refrigeration circuit during operation. Water in the system shall always be avoided. Not only because it can shortly lead to electrical failure, sludge in sump and corrosion but in particular because it can cause serious safety risks.

Corrosion: Materials in the system shall be compliant with water and protected against corrosion.

Common causes for water leaks are corrosion and freezing.

Freezing: When water freezes into ice its volume expands which can damage heat exchanger walls and cause leaks. During off periods water inside heat exchangers could start freezing when ambient temperature is lower than 32°F. During on periods ice banking could occur when the circuit is running continuously at too low load. Both situations should be avoided by connecting a pressure and thermostat switch in the safety line.

Starting sound level

During start-up transients it is natural for the compressor sound level to be slightly higher than during normal running. Danfoss scroll compressors exhibit very little increased start-up transient sound. If a 3-phase model is miswired, the compressor will run in reverse. Reverse

compressor rotation is characterized by an objectionable sound. To correct reverse rotation, disconnect power and switch any two of the three power leads at the unit contactor. Never switch leads at the compressor terminals.

Running sound level

Danfoss scroll compressors are designed with optimised discharge ports and wrap geometry

to reduce the sound level when a compressor is running.

Model	50 Hz		60 Hz	
	Sound power (dBA) Without jacket	Sound power (dBA) With jacket	Sound power (dBA) Without jacket	Sound power (dBA) With jacket
HRM032 - 038	66	61	69	64
HRM040 - 047	67	62	70	65
HRM048 - 054	68	63	71	66
HRM058 - 060	69	64	72	67
HLM068 - 081	70	65	73	68
HCM094	71	66	74	69
HCM109 - 120	74	69	78	73
HRH029 - 032	65	60	68	63
HRH034 - 040	66	61	69	64
HRH041 - 056	67	62	70	65
HLH061	70	65	73	68
HLH068 - HLJ083	71	66	74	69
H CJ090	72	67	75	70
H CJ105 - 120	73	68	76	71
H CJ091 - 106 - 121	72	-	76	-

H*P series same as H*M

Stopping sound level

Danfoss scrolls have very low shutdown sound due to minimal volume of discharge volume to push scrolls in reverse at shutdown. Due to this

small re expansion there is no internal break mechanism required to prevent reverse spin of the scroll set.

Sound generation in a refrigeration system / air conditioning system

Typical sound and vibration in refrigeration and air conditioning systems encountered by design and service engineers may be broken down into the following three source categories.

Sound radiation: This generally takes an airborne path.

Mechanical vibrations: These generally extend along the parts of the unit and structure.

Gas pulsation: This tends to travel through the cooling medium, i.e. the refrigerant.

The following sections will focus on the causes and methods of mitigation for each of the above sources.

Compressor sound radiation

For sound radiating from the compressor, the emission path is airborne and the sound waves are travelling directly from the machine in all directions.

The Danfoss scroll compressor is designed to be quiet and the frequency of the sound generated is pushed into the higher ranges, which not only are easier to reduce but also do not generate the penetrating power of lower-frequency sound.

Use of sound-insulation materials on the inside of unit panels is an effective means of substantially reducing the sound being transmitted to the outside. Ensure that no components capable of transmitting sound/vibration within the unit come into direct contact with any non-insulated parts on the walls of the unit.

Because of the Danfoss's unique design of a full-suction gas & oil cooled motor, compressor body insulation across its entire operating range is possible.

Mechanical vibrations

Vibration isolation constitutes the primary method for controlling structural vibration. Danfoss scroll compressors are designed to produce minimal vibration during operations. The use of rubber isolators on the compressor base plate or on the frame of a manifolded unit is very effective in reducing vibration being transmitted from the compressor(s) to the unit. Rubber grommets are supplied with all Danfoss compressors. Once the supplied rubber grommets have been properly mounted, vibration transmitted from the compressor base plate to the unit are held

to a strict minimum. In addition, it is extremely important that the frame supporting the mounted compressor be of sufficient mass and stiffness to help dampen any residual vibration potentially transmitted to the frame. The tubing should be designed so as to both reduce the transmission of vibrations to other structures and withstand vibration without incurring any damage. Tubing should also be designed for three-dimensional flexibility. For more information on piping design, please see the section entitled "Essential piping design considerations".

Gas pulsation

The Danfoss scroll compressor H-series has been designed and tested to ensure that gas pulsation has been optimised for the most commonly encountered air conditioning pressure ratio. On heat pump installations and other installations where the pressure ratio lies beyond the typical range, testing should be conducted under all

expected conditions and operating configurations to ensure that minimum gas pulsation is present. If an unacceptable level is identified, a discharge muffler with the appropriate resonant volume and mass should be installed. This information can be obtained from the component manufacturer.

Application Guidelines
Installation

Each Danfoss scroll compressor is shipped with printed Instructions for installation. These Instructions can also be downloaded from our

web site www.danfoss.com or directly from: <http://instructions.cc.danfoss.com>

System cleanliness

The refrigerant compression system, regardless of the type of compressor used, will only provide high efficiency and good reliability, along with a long operating life, if the system contains solely the refrigerant and oil it was designed for. Any other substances within the system will not improve performance and, in most cases, will be highly detrimental to system operations.

The presence of non-condensable substances and system contaminants, such as metal shavings, solder and flux, have a negative impact on compressor service life. Many of these contaminants are small enough to pass through a mesh screen and can cause considerable damage within a bearing assembly. The use of highly hygroscopic POE and PVE oils in R407C and R410A compressors requires that the oil be exposed to the atmosphere just as little as possible.

System contamination is one of main factors affecting equipment reliability and compressor service life. It is important therefore to take system cleanliness into account when assembling a refrigeration system.

During the manufacturing process, circuit contamination may be caused by:

- Brazing and welding oxides,
- Filings and particles from the removal of burrs in pipe-work,
- Brazing flux,
- Moisture and air.

Consequently, when building equipment and assemblies, the following precautions must be taken: never drill holes into the pipe-work after installation.

Compressor handling and storage

Compressors are provided with a lifting lug. This lug should always be used to lift the compressor. Once the compressor is installed, the lifting lug should never be used to lift the complete installation. The compressor must be handled

with caution in the vertical position, with a maximum inclination of 15° from vertical. Store the compressor between -30°F and 120°F, not exposed to rain or corrosive atmosphere.

Compressor mounting

Maximum inclination from the vertical plane, while operating must not exceed 7 degrees. All compressors are delivered with 4 rubber

grommets and metal sleeves. Compressors must always be mounted with these grommets.

Compressor holding charge

Each compressor is shipped with a nominal dry nitrogen holding charge between 6 psi and 10 psi, and is sealed with elastomer plugs. The plugs should be removed with care to avoid oil loss when the holding charge is released. Remove the suction plug first and the discharge plug

afterwards. The plugs shall be removed only just before connecting the compressor to the installation in order to avoid moisture entering the compressor. When the plugs are removed, it is essential to keep the compressor in an upright position to avoid oil spillage.

Tube brazing procedure

Do not bend the compressor discharge or suction lines or force system piping into the compressor connections, because this will increase stresses

that are a potential cause of failure. Recommended brazing procedures and material, are described on following page.

Brazing material

For copper suction and discharge fittings, use copper-phosphorus brazing material. Sil-Fos® and other silver brazing materials are also acceptable.

If flux is required for the brazing operation, use coated rod or flux core wire. To avoid system contamination, do not brush flux on.

Compressor connection

When brazing the compressor fittings, do not overheat the compressor shell, which could severely damage certain internal components due to excessive heating. Use of a heat shield and/or a heat-absorbent compound is highly recommended. For brazing the suction and discharge connections, the following procedure is advised:

- Make sure that no electrical wiring is connected to the compressor.
- Protect the terminal box and compressor painted surfaces from torch heat damage (see diagram).
- Use only clean refrigeration-grade copper tubing and clean all connections.
- Purge nitrogen or CO₂ through the compressor in order to prevent against oxidation and flammable conditions. The compressor should not be exposed to the open air for extended periods.
- Use of a double-tipped torch is recommended.
- Apply heat evenly to Area (A) until the brazing temperature is reached. Move the torch to Area (B) and apply heat evenly until the brazing temperature has been reached there as well, and then begin adding the brazing material. Move the torch evenly around the joint, in applying only enough brazing material to flow the full circumference of the joint.
- Move the torch to area (C) only long enough to draw the brazing material into the joint, but not into the compressor.
- Remove all remaining flux once the joint has been soldered with a wire brush or a wet cloth. Remaining flux would cause corrosion of the tubing.

Ensure that no flux is allowed to enter into the tubing or compressor. Flux is acidic and can cause substantial damage to the internal parts of the

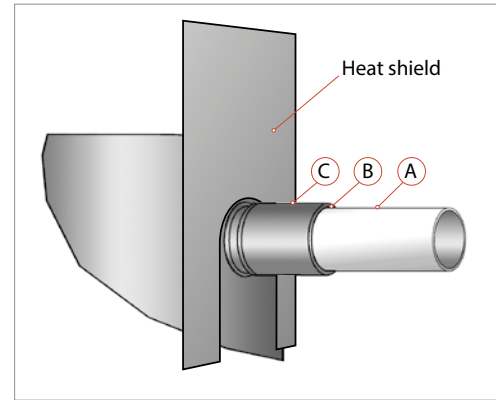

system and compressor.

The POE and PVE oils used in compressors are highly hygroscopic and will rapidly absorb moisture from the air. The compressor must therefore not be left open to the atmosphere for a long period of time. The compressor fitting plugs shall be removed just before brazing the compressor.

⚠ Before eventual unbrazing the compressor or any system component, the refrigerant charge must be removed from both the high and low pressure sides. Failure to do so may result in serious personal injury. Pressure gauges must be used to ensure all pressures are at atmospheric level.

For more detailed information on the appropriate materials required for brazing or soldering, please contact the product manufacturer or distributor. For specific applications not covered herein, please contact Danfoss Commercial Compressors for further information.

Vacuum evacuation and moisture removal

Moisture obstructs the proper functioning of both the compressor and the refrigeration system.

Air and moisture reduce service life and increase condensing pressure, which causes abnormally high discharge temperatures that are then capable of degrading the lubricating properties of the oil. The risk of acid formation is also increased by air and moisture, and this condition can also lead to copper plating. All these phenomena may

cause both mechanical and electrical compressor failures. The typical method for avoiding such problems is a vacuum pump-down executed with a vacuum pump, thus creating a minimum vacuum of 0.02 in Hg (500 μm Hg). Please refer to Bulletin "Vacuum pump down and dehydration procedure".

Be sure to follow all government regulations regarding refrigerant reclamation and storage.

Application Guidelines**Installation**

Liquid line filter driers

A properly sized filter drier is required for all Danfoss scroll applications. Danfoss recommends DCL (solid core) driers for HCFC refrigerants with mineral oil, and DML (100% molecular sieves) driers for HFC refrigerants R407C and R410A with POE or PVE oil. For servicing of existing installations where acid formation is present the

Danfoss DCL solid core filter driers containing activated alumina are recommended. The drier is to be oversized rather than under sized. When selecting a drier, always take into account its capacity (water content capacity), the system refrigeration capacity and the system refrigerant charge.

Refrigerant charging

It is recommended that system charging be done using the weighed charge method, adding refrigerant to the high side of the system. Charging the high and low sides of a system

with gas simultaneously at a controlled rate is also an acceptable method. Do not exceed the recommended unit charge, and never charge liquid to the low side.

Insulation resistance and dielectric strength

Insulation resistance must be greater than 1 megohm when measured with a 500 volt direct current megohm tester.

Each compressor motor is tested at the factory with a high potential voltage (hi-pot) that exceeds the UL requirement both in potential and in duration. Leakage current is less than 0.5 mA.

Danfoss scroll compressors are configured with the pump assembly at the top of the shell, and the motor below. As a result, the motor can be partially immersed in refrigerant and oil. The presence of

refrigerant around the motor windings will result in lower resistance values to ground and higher leakage current readings. Such readings do not indicate a faulty compressor, and should not be cause for concern.

In testing insulation resistance, Danfoss recommends that the system be first operated briefly to distribute refrigerant throughout the system. Following this brief operation, retest the compressor for insulation resistance or current leakage.

Compressor replacement after motor burn out

If there has been a motor burnout follow the evacuation procedure described on previous page. Remove and replace the liquid line filter drier and install a Danfoss type DAS burnout drier of appropriate capacity.

Refer to the DAS drier instructions and technical information on correct use and monitoring of the burnout drier and the liquid line and suction line filter driers.

Packaging

Single pack

Compressors are packed individually in a cardboard box. They can be ordered in any quantity. Minimum ordering quantity = 1. As far as possible, Danfoss will ship the boxes on full pallets of 8 or 16 compressors according below table.

- Each box also contains following accessories:
- 4 grommets
- 4 assemblies of self tapping US thread bolts, washers and sleeves
- 4 additional sleeves
- 1 screw for earth connection
- Depending on model and shipping type a run capacitor may be included (see table).

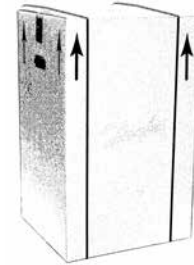

Industrial pack

Compressors are not packed individually but are shipped all together on one pallet. They can be ordered in quantities of full pallets only, multiples of 12 or 16 compressors, according below table.

Each industrial pack pallet contains following accessories:

- 4 grommets per compressor
- 4 sleeves per compressor

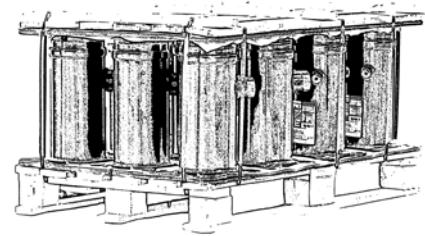

Packaging details

According to delivery region, packaging dimensions and compressor quantities are different.

See below for details.

Delivered region	Packaging	Nbr	Pallet type	Comments
Americas Asia Pacific Middle East	Single pack	16	US pallet	Optimised for overseas container loading
	Industrial pack	16	US pallet	
Europe	Single pack	8	Danfoss pallet	-
	Industrial pack	12	Danfoss pallet	

* Nbr : number of compressors/pallet

For CN made H series compressors (code number starting with 121L)

Delivered region	Packaging	Nbr	Pallet type	Comments
All	Single pack	6	Danfoss pallet	-
	Industrial pack	12	Danfoss pallet	

* Nbr : number of compressors/pallet

R22 Single pack

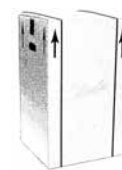

Compressors	Model Variation	Connections	Features	Code no.					
				1	2	4	5	7	9
HRM032	U	P	6	120U0921	120U2029	120U0996			
	T	P	6				120U0956		
HRM034	U	P	6	120U0926	120U1081	120U1001		120U2232	
	T	P	6			120U2367	120U2122		120U2087
HRM038	U	P	6	120U0931	120U1091	120U1011	120U0966	120U1056	
	T	P	6			120U2372	120U2137		120U2092
HRM040	U	P	6	120U0936	120U1101	120U1021	120U2147	120U1061	
	T	P	6			120U2377	120U2142		120U2462
HRM042	U	P	6	120U0941	120U1111	120U1031	120U0971	120U1066	
	T	P	6			120U2127	120U2152		120U2107
HRM045	U	P	6	120U0946	120U1121	120U1041	120U0981	120U1071	
HRM047	U	P	6	120U0951	120U1131	120U1051	120U0991	120U1076	
	T	P	6			120U2132	120U2162		120U2097
HRM048	U	C	8			120U1671			
	U	P	6	120U1496		120U1666		120U1791	
HRM051	T	P	6			120U1676	120U2187		120U2382
	U	P	6	120U1506	120U1866	120U1686	120U2252	120U1801	
HRM054	U	C	6	120U1516					
	U	P	6	120U1511	120U1871	120U1696	120U2257	120U1811	
	T	P	6						120U2292
HRM058	T	C	6	120U1526					
	T	P	6	120U1521					120U2112
	U	C	6	120U1536					
	U	P	6	120U1531	120U1876	120U1711	120U1601	120U1821	
HRM060	T	P	6	120U1541		120U1721			120U2082
	T	C	6	120U2242					
	U	C	6	120U1551	120U2077				
	U	C	8			120U1741			
	U	P	6	120U1546	120U1881	120U1736	120U1611	120U1831	
HLM068	T	C	6		120U1891	120U1746		120U2598	120U2392
	T	P	6	120U1556			120U1616		
HLM072	T	C	6		120U1896	120U1751		120U2602	120U1856
	T	C	8		120U2202	120U2067			
	T	P	6	120U1566			120U1626		
HLM075	T	C	6		120U1901	120U1761		120U1836	
	T	P	6	120U1576			120U1636		
HLM078	T	C	6		120U1906	120U1771			
HLM081	T	C	6		120U1911	120U1776		120U1846	120U2102
	T	C	8			120U2009			
	T	P	6	120U1586			120U1646		
HCM094	T	C	6		120U0891	120U0581		120U0711	120U0746
	T	C	7			120U0586			
	T	C	8		120U0901	120U0596		120U0721	120U0756
HCM109	T	C	6		120U2506	120U0366			
	T	C	7			120U0371			
	T	C	8			120U1924			
HCM120	T	C	6		120U0761	120U0391			
	T	C	7		120U2212	120U0396			
	T	C	8		120U2217	120U2207			

R22 Industrial pack

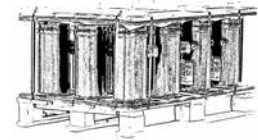

Compressors	Model Variation	Connections	Features	Code no.					
				1	2	4	5	7	9
HRM032	U	P	6	120U0918	120U2026	120U0993			
	T	P	6				120U0953		
HRM034	T	P	6			120U2364	120U2119		120U2084
	U	P	6	120U0923	120U1078	120U0998		120U2229	
HRM038	T	P	6			120U2369	120U2134		120U2089
	U	P	6	120U0928	120U1088	120U1008	120U0963	120U1053	
HRM040	T	P	6			120U2374	120U2139		120U2459
	U	P	6	120U0933	120U1098	120U1018	120U2144	120U1058	
HRM042	T	P	6			120U2124	120U2149		120U2104
	U	P	6	120U0938	120U1108	120U1028	120U0968	120U1063	
HRM045	U	P	6	120U0943	120U1118	120U1038	120U0978	120U1068	
	T	P	6			120U2129	120U2159		120U2094
HRM047	U	P	6	120U0948	120U1128	120U1048	120U0988	120U1073	
	U	C	8			120U1668			
HRM048	U	P	6	120U1493		120U1663		120U1788	
	T	P	6			120U1673	120U2184		120U2379
HRM051	U	P	6	120U1503	120U1863	120U1683	120U2249	120U1798	
	T	P	6						120U2289
HRM054	U	C	6	120U1513					
	U	P	6	120U1508	120U1868	120U1693	120U2254	120U1808	
HRM058	T	C	6	120U1523					
	T	P	6	120U1518					120U2109
	U	C	6	120U1533					
	U	C	8			120U1716			
HRM060	U	P	6	120U1528	120U1873	120U1708	120U1598	120U1818	
	T	C	6	120U2239					
	T	P	6	120U1538		120U1718			120U2079
	U	C	6	120U1548	120U2074				
	U	C	8			120U1738			
HLM068	U	P	6	120U1543	120U1878	120U1733	120U1608	120U1828	
	T	C	6		120U1888	120U1743		120U2595	120U2389
HLM072	T	C	6		120U1893	120U1748		120U2599	120U1853
	T	C	8		120U2199	120U2064			
HLM075	T	P	6	120U1563			120U1623		
	T	C	6		120U1898	120U1758		120U1833	
HLM078	T	P	6	120U1573			120U1633		
	T	C	6		120U1903	120U1768			
HLM081	T	C	6		120U1908	120U1773		120U1843	120U2099
	T	C	8			120U2006			
	T	P	6	120U1583			120U1643		
HCM094	T	C	6		120U0888	120U0578		120U0708	120U0743
	T	C	7			120U0583			
	T	C	8		120U0898	120U0593		120U0718	120U0753
HCM109	T	C	6		120U2503	120U0363			
	T	C	7			120U0368			
HCM120	T	C	8			120U1921			
	T	C	6		120U0758	120U0388			
	T	C	7		120U2209	120U0393			
	T	C	8		120U2214	120U2204			

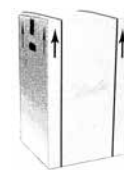
R407C Single pack

Compressors	Model Variation	Connections	Features	Code no.					
				1	2	4	5	7	9
HRP034	T	P	6			120U2024	120U2019		
HRP038	T	P	6		120U1086	120U1006	120U0961		
HRP040	T	P	6		120U1096	120U1016	120U1929		
HRP042	T	P	6		120U1106	120U1026	120U2157		
HRP045	T	P	6		120U1116	120U1036	120U0976		
HRP047	T	P	6		120U1126	120U1046	120U0986		
HRP048	T	C	8			120U1661			
HRP048	T	P	6			120U1656			
HRP051	T	P	6	120U1501	120U1861	120U1681	120U2192	120U1796	
HRP054	T	P	6			120U1691	120U2197	120U1806	
	T	C	8			120U2004			
HRP058	T	C	8			120U1706			
	T	P	6			120U1701	120U1596	120U1816	
HRP060	T	C	8			120U1731			
	T	P	6		120U2297	120U1726	120U1606	120U1826	
HLP068	T	C	6			120U2014			
	T	P	6	120U1561			120U1621		
HLP072	T	C	6			120U1756			
	T	C	8			120U2072			
	T	P	6	120U1571			120U1631		
HLP075	T	C	6			120U1766		120U1841	
	T	P	6	120U1581			120U1641		
HLP078	T	C	6		120U2458	120U2454			
HLP081	T	C	6		120U1916	120U1781		120U1851	
	T	C	8			120U1786			
	T	P	6	120U1591			120U1651		
HCP094	T	C	6		120U0906	120U0601			
	T	C	7		120U0911	120U0606			
	T	C	8		120U0916	120U0611			
HCP109	T	C	6			120U0376			
	T	C	7			120U0381			
	T	C	8			120U0386			
HCP120	T	C	6		120U0766	120U0401			
	T	C	7		120U2222	120U0406			
	T	C	8		120U2227	120U0411			

R407C Industrial pack

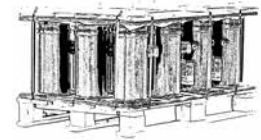

Compressors	Model Variation	Connections	Features	Code no.					
				1	2	4	5	7	9
HRP034	T	P	6			120U2021	120U2016		
HRP038	T	P	6		120U1083	120U1003	120U0958		
HRP040	T	P	6		120U1093	120U1013	120U1926		
HRP042	T	P	6		120U1103	120U1023	120U2154		
HRP045	T	P	6		120U1113	120U1033	120U0973		
HRP047	T	P	6		120U1123	120U1043	120U0983		
HRP048	T	C	8			120U1658			
HRP048	T	P	6			120U1653			
HRP051	T	P	6	120U1498	120U1858	120U1678	120U2189	120U1793	
HRP054	T	P	6			120U1688	120U2194	120U1803	
	T	C	8			120U2001			
HRP058	T	C	8			120U1703			
	T	P	6			120U1698	120U1593	120U1813	
HRP060	T	C	8			120U1728			
	T	P	6		120U2297	120U1723	120U1603	120U1823	
HLP068	T	C	6			120U2011			
	T	P	6	120U1558			120U1618		
HLP072	T	C	6			120U1753			
	T	C	8			120U2074			
	T	P	6	120U1568			120U1628		
HLP075	T	C	6			120U1763		120U1838	
	T	P	6	120U1578			120U1638		
HLP078	T	C	6		120U2455	120U2451			
HLP081	T	C	6		120U1913	120U1778		120U1848	
	T	C	8			120U1783			
	T	P	6	120U1588			120U1648		
HCP094	T	C	6		120U0903	120U0598			
	T	C	7		120U0908	120U0603			
	T	C	8		120U0913	120U0608			
HCP109	T	C	6			120U0373			
	T	C	7			120U0378			
	T	C	8			120U0383			
HCP120	T	C	6		120U0763	120U0398			
	T	C	7		120U2219	120U0403			
	T	C	8		120U2224	120U0408			

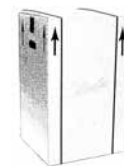
R410A Single pack

Compressors	Model Variation	Connections	Features	Code no.					
				1	2	4	5	7	9
HRH029	U	P	6	120U2277	120U2282	120U2287			
HRH031	U	P	6	120U1136	120U1251	120U1191	120U1166	120U1216	
HRH032	U	P	6	120U1141	120U1256	120U1196	120U1171	120U1221	
HRH034	U	P	6	120U1146	120U1261	120U2446	120U2650	120U1226	120U2654
HRH036	U	P	6	120U1151	120U1266	120U1201	120U1176	120U1231	
HRH038	U	P	6	120U1156	120U1271	120U1206	120U1181	120U1236	120U2658
HRH039	U	P	6	120U2466					
HRH040	U	P	6	120U1161	120U1276	120U1211	120U1186	120U1241	
HRH041	U	P	6	120U1281	120U1451	120U1356		120U1406	
	U	C	6		120U2412				
	U	C	8		120U2407	120U2397		120U2402	
HRH044	U	P	6	120U1286	120U1456	120U1361		120U1411	
HRH047	U	P	6	120U2362					
HRH048	U	P	6	120U2582					
HRH049	U	P	6	120U1291	120U1461	120U1366		120U1416	
	U	C	8		120U2482	120U2474		120U2478	
HRH050	U	P	6	120U2470					
HRH051	U	P	6	120U1296	120U1466	120U1371	120U1326	120U1421	
HRH054	U	P	6	120U1301	120U1471	120U1376	120U1331	120U1426	
HRH056	U	C	6			120U1386		120U2237	
	U	P	6	120U1306	120U1476	120U1381	120U1336	120U1431	
HLH061	T	C	6		120U2062	120U2052		120U2057	120U2450
	T	P	6	120U2042			120U2047		
	T	C	8		120U2494	120U2486		120U2490	
	T	C	T		121L3169	121L3167			
HLH068	T	C	6		120U1481	120U1391		120U1436	
	T	P	6	120U1311			120U1341		
HLJ072	T	C	8		120U2427	120U2417		120U2422	
	T	C	6		120U1486	120U1396		120U2037	
	T	P	6	120U1316			120U1346		
HLJ075	T	C	8		120U2177	120U2167		120U2498	
	T	C	T		121L3173	121L3171			
	T	C	6		120U2272	120U2267		120U2262	
HLJ083	T	C	8		120U2442	120U2432		120U2437	
	T	C	6	120U1321	120U1491	120U1401		120U1441	120U2387
	T	P	6				120U1351		
	T	C	8		120U2182	120U2172		120U2502	
HCJ090	T	C	T		121L3177	121L3175			
	T	C	6		120U2307	120U2302		120U2312	
	T	C	7		120U2542	120U2534		120U2510	
HCJ091	T	C	8		120U2546	120U2538		120U2514	
	T	C	6			121L3113			
	T	C	8			121L3119			
HCJ105	T	C	6		120U2327	120U2322		120U2332	
	T	C	7		120U2550	120U2574		120U2518	
	T	C	8		120U2554	120U2578		120U2522	
HCJ106	T	C	6			121L3115			
	T	C	8			121L3121			
HCJ120	T	C	6		120U2347	120U2342		120U2352	
	T	C	7		120U2566	120U2558		120U2526	
	T	C	8		120U2570	120U2562		120U2530	
HCJ121	T	C	6			121L3117			
	T	C	8			121L3123			

R410A Industrial pack

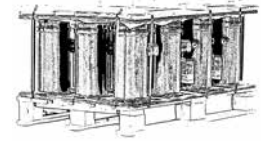

Compressors	Model Variation	Connections	Features	Code no.					
				1	2	4	5	7	9
HRH029	U	P	6	120U2274	120U2279	120U2284			
HRH031	U	P	6	120U1133	120U1248	120U1188	120U1163	120U1213	
HRH032	U	P	6	120U1138	120U1253	120U1193	120U1168	120U1218	
HRH034	U	P	6	120U1143	120U1258	120U2443	120U2647	120U1223	120U2651
HRH036	U	P	6	120U1148	120U1263	120U1198	120U1173	120U1228	
HRH038	U	P	6	120U1153	120U1268	120U1203	120U1178	120U1233	120U2655
HRH039	U	P	6	120U2463					
HRH040	U	P	6	120U1158	120U1273	120U1208	120U1183	120U1238	
HRH041	U	P	6	120U1278	120U1448	120U1353		120U1403	
	U	C	6		120U2409				
	U	C	8		120U2404	120U2394		120U2399	
HRH044	U	P	6	120U1283	120U1453	120U1358		120U1408	
HRH047	U	P	6	120U2359					
HRH048	U	P	6	120U2579					
HRH049	U	P	6	120U1288	120U1458	120U1363		120U1413	
	U	C	8		120U2479	120U2471		120U2475	
HRH050	U	P	6	120U2467					
HRH051	U	P	6	120U1293	120U1463	120U1368	120U1323	120U1418	
HRH054	U	P	6	120U1298	120U1468	120U1373	120U1328	120U1423	
HRH056	U	C	6			120U1383		120U2234	
HRH056	U	P	6	120U1303	120U1473	120U1378	120U1333	120U1428	
HLH061	T	P	6	120U2039			120U2044		
	T	C	6		120U2059	120U2049		120U2054	120U2447
	T	C	8		120U2491	120U2483		120U2487	
	T	C	T		121L3168	121L3166			
HLH068	T	C	6		120U1478	120U1388		120U1433	
	T	C	8		120U2424	120U2414		120U2419	
	T	P	6	120U1308			120U1338		
HLJ072	T	C	6		120U1483	120U1393		120U2034	
	T	C	8		120U2174	120U2164		120U2495	
	T	P	6	120U1313			120U1343		
	T	C	T		121L3172	121L3170			
HLJ075	T	C	6		120U2269	120U2264		120U2259	120U1443
	T	C	8		120U2439	120U2429		120U2434	
HLJ083	T	C	6		120U1488	120U1398		120U1438	120U2384
	T	C	8		120U2179	120U2169		120U2499	
	T	P	6	120U1318			120U1348		
HCJ090	T	C	T		121L3176	121L3174			
	T	C	6		120U2304	120U2299		120U2309	
	T	C	7		120U2539	120U2531		120U2507	
	T	C	8		120U2543	120U2535		120U2511	
HCJ091	T	C	6			121L3112			
	T	C	8			121L3118			
HCJ105	T	C	6		120U2324	120U2319		120U2329	
	T	C	7		120U2547	120U2571		120U2515	
	T	C	8		120U2551	120U2575		120U2519	
HCJ106	T	C	6			121L3114			
	T	C	8			121L3120			
HCJ120	T	C	6		120U2344	120U2339		120U2349	
	T	C	7		120U2563	120U2555		120U2523	
	T	C	8		120U2567	120U2559		120U2527	
HCJ121	T	C	6			121L3116			
	T	C	8			121L3122			

Run capacitors for PSC wiring



Type	Code n°	Description	Application	Packaging	Pack size
70 µF	120Z0051	PSC wiring Run Capacitor 70 µF, motor voltage code 5 - 220-240V / 1 / 50Hz	HRM032-034-038-040-042 - HRP034-038-040-042 - HRH031-032-036	Multipack	10
60 µF	120Z0050	PSC wiring Run Capacitor 60 µF, code 5	HRM045-047 - HRP045-047 - HRH038-040	Multipack	10
55 µF	8173234	PSC wiring Run Capacitor 55 µF, motor voltage code 5 - 220-240V / 1 / 50Hz	HRM054-058-060 / HLM068-072-075-081 - HRP054-058-060 / HLP068-072-075-081 - HRH051-054-056 / HLH068 / HLJ072-083 / HLH061	Multipack	10

Start capacitors and starting relay for CSR wiring



Type	Code n°	Description	Application	Packaging	Pack size
145-175 µF	120Z0399	CSR wiring Start Capacitor 145-175 µF, motor voltage code 5 - 220-240V / 1 / 50Hz	HRM/P032-034-038-040-042-045-047 HRH029-031-032-036-038-040	Multipack	10
161-193 µF	120Z0400	CSR wiring Start Capacitor 161-193 µF, motor voltage code 5 - 220-240V / 1 / 50Hz	HRM/P051-054	Multipack	10
88-108 µF	8173001	CSR wiring Start Capacitor 88-108 µF, motor voltage code 5 - 220-240V / 1 / 50Hz	HRM/P058-060 HLM/P068-072-075-081 HRH051-054-056 HLH068 HLJ072-083	Multipack	10
RVA9CKL	120Z0393	CSR wiring Starting Relay, motor voltage code 5 - 220-240V / 1 / 50Hz	HRM/P032-034-038-040-042-045-047 HRH029-031-032-036-038-040	Multipack	10
RVA3EKL	120Z0394	CSR wiring Starting Relay, motor voltage code 5 - 220-240V / 1 / 50Hz	HRM/P051-054	Multipack	10
RVA4GKL	120Z0395	CSR wiring Starting Relay, motor voltage code 5 - 220-240V / 1 / 50Hz	HRM/P058-060 HLM/P068-072-075-081 HRH051-054-056 HLH068 HLJ072-083 HLH061	Multipack	10

Rotolock adaptor set



Type	Code n°	Description	Application	Packaging	Pack size
	120Z0126	Rotolock adaptor set (1-1/4" ~ 3/4") , (1" ~ 1/2")	HRP/HRM025-034-038-040-042 HRH029-031-032-034-036038 - group 1	Multipack	6
	120Z0127	Rotolock adaptor set (1-1/4" ~ 7/8") , (1" ~ 1/2")	HRP/HRM045-047-051-057-058-060-068-072-075 HRH040-041-044-049-051-056-061-068-072-075-083 - group 2	Multipack	6
	120Z0128	Rotolock adaptor set (1-1/4" ~ 7/8") , (1-1/4" ~ 3/4")	HRM/HRP078-081 - group 3	Multipack	6
	120Z0129	Rotolock adaptor set (1-3/4" ~ 1-1/8") , (1-1/4" ~ 7/8")	HCM/P094-109-120 H CJ090-091-105-106-120-121 - group 4	Multipack	6

Rotolock adaptor



Type	Code n°	Description	Application (see above group)	Packaging	Pack size
	120Z0366	Rotolock adaptor (1-1/4" ~ 3/4")	Group 1 suction	Multipack	10
	120Z0367	Rotolock adaptor (1-1/4" ~ 7/8")	Group 2 & 3 suction	Multipack	10
	120Z0364	Rotolock adaptor (1-3/4" ~ 1-1/8")	Group 4 suction	Multipack	10
	120Z0365	Rotolock adaptor (1" ~ 1/2")	Group 1 & 2 discharge	Multipack	10
	120Z0366	Rotolock adaptor (1-1/4" ~ 3/4")	Group 3 discharge	Multipack	10
	120Z0367	Rotolock adaptor (1-1/4" ~ 7/8")	Group 4 discharge	Multipack	10

Crankcase heater



Type	Code No	Description	Application	Packaging	Pack Size
	120Z0055	Belt type crankcase heater, 40 W, 230 V, CE mark	HRM032-034-038-040-042-045-047 - HRP025-038-040-042-045-047 - HRH029-032-034-036-038-040	Multipack	6
	120Z0056	Belt type crankcase heater, 40 W, 400 V, CE mark		Multipack	6
	120Z0057	Belt type crankcase heater, 50 W, 230 V, CE mark	HRM048-051-054-058-060 / HLM068-072-075 - HRP048-051-054-058-060 / HLP068-072-075 - HRH041-049-051-054-056 / HLH061-068 / HLJ072 / HLJ075	Multipack	6
	120Z0058	Belt type crankcase heater, 50 W, 400 V, CE mark		Multipack	6
	120Z0059	Belt type crankcase heater, 65 W, 230 V, CE mark, UL		Multipack	6
	120Z5011	Belt type crankcase heater, 70 W, 230 V, UL, CE mark	HLM078-081 / HCM094-109-120 - HLP081 / HCP094-109-120 - HLJ083 - HCJ090-091-105-106-120-121	Multipack	6
	120Z0060	Belt type crankcase heater, 65 W, 400 V, CE mark, UL		Multipack	6
	120Z5012	Belt type crankcase heater, 70 W, 460 V, UL, CE mark		Multipack	6
	120Z5013	Belt type crankcase heater, 70 W, 575 V, UL, CE mark		Multipack	6
	120Z5038	Belt Type crankcase heater, 40 W, 460 V, UL	HRM/P025-047, HRH029-040	Multipack	6

Discharge temperature protection



Type	Code No	Description	Application	Packaging	Pack Size
	7750009	Discharge thermostat kit	All models	Multipack	10
	7973008	Discharge thermostat kit	All models	Industry pack	50

Lubricant



Type	Code No	Description	Application	Packaging	Pack Size
	120Z5034	PVE (0.95 liter can)	HRH, HLH, HLJ, HCJ, HRP, HLP & HCP	Multipack	1



Mounting hardware

Type	Code No	Description	Application	Packaging	Pack Size
	120Z5017	Mounting grommet	All models	Single pack	1
	120Z5014	Mounting sleeve	All models	Single pack	1
	120Z5031	Mounting kit, including 1 bolt, 1 sleeve, 1 washer	All models	Single pack	1
	120Z5005	Mounting kit for 1 scroll compressor including 4 grommets, 4 sleeves, 4 bolts, 4 washers	All models	Single pack	1



Terminal box

Code No	Description	Application	Packaging	Pack Size
120Z5015	Round terminal box (P & T version)	P and T version	Multipack	10
120Z5018	Square terminal box (C & Q version)	C and Q version	Multipack	10

Previous version

- Page 7: Nomenclature.
- Page 40: R410A Single pack.
- Page 41: R410A Industrial pack.

Current version

- Page 7: Updated Nomenclature with “T” feature.
- Page 15: Added outline diagram for HLH061-HLJ072-HLJ083.
- Page 41: Added new codes for HLH061-HLJ072-HLJ083 in R410A Single pack.
- Page 42: Added new codes for HLH061-HLJ072-HLJ083 in R410A Industrial pack.

Danfoss Commercial Compressors

is a worldwide manufacturer of compressors and condensing units for refrigeration and HVAC applications. With a wide range of high quality and innovative products we help your company to find the best possible energy efficient solution that respects the environment and reduces total life cycle costs.

We have 40 years of experience within the development of hermetic compressors which has brought us amongst the global leaders in our business, and positioned us as distinct variable speed technology specialists. Today we operate from engineering and manufacturing facilities spanning across three continents.



Danfoss Scrolls

Danfoss Inverter Scrolls

Danfoss Turbocor Compressors

Danfoss Optyma Condensing Units

Danfoss Maneurop Reciprocating Compressors

Secop Compressors for Danfoss

Our products can be found in a variety of applications such as rooftops, chillers, residential air conditioners, heatpumps, coldrooms, supermarkets, milk tank cooling and industrial cooling processes.

<http://danfoss.us.com>

Danfoss Commercial Compressors, BP 331, 01603 Trévoux Cedex, France | +334 74 00 28 29



Danfoss can accept no responsibility for possible errors in catalogues, brochures and other printed material. Danfoss reserves the right to alter its products without notice. This also applies to products already on order provided that such alterations can be made without consequential changes being necessary in specifications already agreed. All trademarks in this material are property of the respective companies. Danfoss and the Danfoss logotype are trademarks of Danfoss A/S. All rights reserved.